

# **Agilent 5977B Series MSD**

## **Troubleshooting and Maintenance Manual**



**Agilent Technologies**

# Notices

© Agilent Technologies, Inc. 2016

No part of this manual may be reproduced in any form or by any means (including electronic storage and retrieval or translation into a foreign language) without prior agreement and written consent from Agilent Technologies, Inc. as governed by United States and international copyright laws.

## Manual Part Number

G7077-90025

## Edition

First edition, June 2016

Printed in USA

Agilent Technologies, Inc.  
5301 Stevens Creek Boulevard  
Santa Clara, CA 95052

## Warranty

**The material contained in this document is provided “as is,” and is subject to being changed, without notice, in future editions. Further, to the maximum extent permitted by applicable law, Agilent disclaims all warranties, either express or implied, with regard to this manual and any information contained herein, including but not limited to the implied warranties of merchantability and fitness for a particular purpose. Agilent shall not be liable for errors or for incidental or consequential damages in connection with the furnishing, use, or performance of this document or of any information contained herein. Should Agilent and the user have a separate written agreement with warranty terms covering the material in this document that conflict with these terms, the warranty terms in the separate agreement shall control.**

## Safety Notices

### CAUTION

A **CAUTION** notice denotes a hazard. It calls attention to an operating procedure, practice, or the like that, if not correctly performed or adhered to, could result in damage to the product or loss of important data. Do not proceed beyond a **CAUTION** notice until the indicated conditions are fully understood and met.

### WARNING

A **WARNING** notice denotes a hazard. It calls attention to an operating procedure, practice, or the like that, if not correctly performed or adhered to, could result in personal injury or death. Do not proceed beyond a **WARNING** notice until the indicated conditions are fully understood and met.

## 1 Introduction

5977B Series MSD Version	10
Abbreviations Used	11
The 5977B Series MSD	13
MSD Hardware Description	16
EI systems	17
CI systems	17
Changing modes	18
Important Safety Warnings	19
Hydrogen Safety	22
Safety and Regulatory Certifications	27
Cleaning/Recycling the Product	30
Moving or Storing the MSD	30
To Replace the Primary Fuses	31

## 2 General Troubleshooting

Front Panel Instrument Status LED	34
Troubleshooting Tips and Tricks	35
General Symptoms	36
Chromatographic Symptoms	38
Mass Spectral Symptoms	43
Pressure Symptoms	47
Temperature Symptoms	50
Error Messages	52
Air Leaks	58
Contamination	59

### **3 CI Troubleshooting**

Common CI-Specific Problems	62
Troubleshooting Tips and Tricks	63
Air Leaks	64
Pressure-Related Symptoms	68
Signal-Related Symptoms	72
Tuning-Related Symptoms	81

### **4 General Maintenance**

Before Starting	88
Maintaining the Vacuum System	93
To Separate the MSD from the GC	94
To Move or Store the MSD	96
To Reconnect the MSD to the GC	98
To Check the Foreline Pump Fluid	99
To Drain the Foreline Pump	101
To Refill the Foreline Pump	102
To Change the Blue Oil Mist Filter on the Foreline Pump	103
To Install the Exhaust Filter on the IDP3 Dry Pump	104
To Change the Filter Cartridge on the IDP3 Dry Foreline Pump	105
To Check the DP Fluid	106
To Remove the DP	108
To Replace the DP Fluid	110
To Install the DP	113
To Remove the Foreline Gauge	115



To Install the Foreline Gauge	117
To Refill the EI Calibration Vial	118
To Purge the Calibration Valves	120
To Remove the EI Calibration and Vent Valve Assembly	121
To Install the EI Calibration and Vent Valve Assembly	122
To Replace the Fan for the High Vacuum Pump	123
To Remove the Ion Vacuum Gauge	125
To Install an Ion Vacuum Gauge	126
To Lubricate the Side Plate O-Ring	127
To Lubricate the Vent Valve O-Ring	129
Maintaining the Electronics	131
To Adjust the Quad Frequency	133
To Replace the Primary Fuses	135

## 5 CI Maintenance

To Replace the Methane/Isobutane Gas Purifier	138
To Clean the Reagent Gas Supply Lines	139
To Refill the CI Calibrant Vial	140

## 6 Vacuum System

Overview	144
Vacuum System Components	145
Common Vacuum System Problems	146
Foreline Pump	147
High Vacuum Pump	151
DP system	151
Turbo pump system	151

Analyzer Chamber	152
DP version	152
Turbo pump version	152
Side Plate	153
Vacuum Seals	156
Foreline Gauge	158
DP and Fan	159
Turbo Pump and Fan	165
Calibration Valves and Vent Valve	166
Micro-Ion Vacuum Gauge	169

## **7 Analyzer**

Overview	172
EI Source	174
EI HES Source	181
CI Source	184
Filaments	188
Other Source Elements	190
Quadrupole Mass Filter	192
Detector	195
Analyzer Heaters and Radiators	197

## **8 Electronics**

Local User Interface, Power Switch, and Front Panel LED	200
Front panel instrument status LED	200
Side Board	202
Electronics Module	203

LAN/MS Control Card	207
Power Supplies	208
Back Panel and Connectors	209
High vacuum gauge connector	210
Interfacing to External Devices	212

## **9 Parts**

To Order Parts	216
Electronics	217
Vacuum System	218
Analyzer	226
Consumables and Maintenance Supplies	240



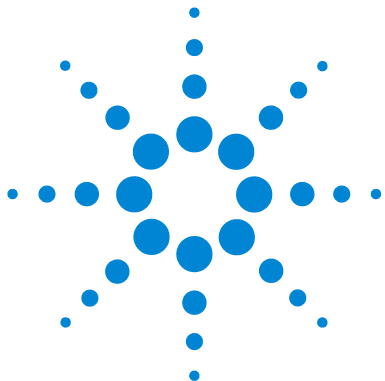

# 1 Introduction

5977B Series MSD Version	10
Abbreviations Used	11
The 5977B Series MSD	13
MSD Hardware Description	16
Important Safety Warnings	19
Hydrogen Safety	22
Safety and Regulatory Certifications	27
Cleaning/Recycling the Product	30
Moving or Storing the MSD	30
To Replace the Primary Fuses	31

This manual describes the troubleshooting and maintenance of the Agilent 5977B Series Mass Selective Detector (MSD). It assumes familiarity with the procedures and information detailed in the 5977B Series MSD or 5975/77 Series for OpenLAB CDS Operating Manual, and with the accompanying software.

## 5977B Series MSD Version

The 5977B Series MSDs are equipped with a turbomolecular (turbo) pump and a choice of four foreline pumps or a DP paired with a Pfeiffer DUO 2.5 foreline pump. There are four types of EI sources, a standard stainless steel EI source, an inert EI source, an EI Extractor (XTR) source available on the Inert+ MSD model, and a high efficiency ion source (HES). A chemical ionization (CI) source includes a reagent flow control system, a CI calibration system, and other required hardware features. The serial number label displays a product number that indicates what type of MSD you have. (See [Table 1.](#))

**Table 1** Available high vacuum pumps

Model name	Product number	Description	Ionization mode/Type
5977B MSD Diff Pump	G7080B	DP	EI/Stainless Steel
5977B MSD Turbo Pump	G7081B	Turbo pump	EI/Stainless Steel
5977B Inert+ EI MSD Turbo	G7077B	Turbo pump MSD	EI/XTR
5977B Inert+ EI/CI MSD Turbo	G7078B	Turbo pump MSD	EI /XTR CI /PCI, NCI
5977B HES MSD Turbo	G7079B	Turbo pump	EI/High Efficiency

## Abbreviations Used

The abbreviations are used in discussing this product. They are collected here for convenience. (See [Table 2.](#))

**Table 2** Abbreviations

<b>Abbreviation</b>	<b>Definition</b>
AC	Alternating current
ALS	Automatic liquid sampler
BFB	Bromofluorobenzene (calibrant)
CI	Chemical ionization
DA	Data analysis
DC	Direct current
DFTPP	Decafluorotriphenylphosphine (calibrant)
DIP	Direct insertion probe
DP	Diffusion pump
DS	Data system
EI	Electron impact ionization
EM	Electron multiplier (detector)
EMV	Electron multiplier voltage
EPC	Electronic pneumatic control
eV	Electron volt
FW	Firmware
GC	Gas chromatograph
HED	High-energy dynode (refers to detector and its power supply)
HES	High efficiency source
id	Inside diameter
Inert	Standard EI source constructed from inert materials

**Table 2** Abbreviations (continued)

<b>Abbreviation</b>	<b>Definition</b>
Inert+	MSD model designation equipped with and EI XTR source
LAN	Local Area Network
LCP	Local control panel (on the GC)
LVDS	Low voltage data signal
<i>m/z</i>	Mass to charge ratio
MFC	Mass flow controller
MSD	Mass selective detector
NCI	Negative CI
OFN	Octafluoronaphthalene (calibrant)
PCI	Positive CI
PFDTD	Perfluoro-5,8-dimethyl-3,6,9-trioxydodecane (calibrant)
PFHT	2,4,6- <i>tris</i> (perfluoroheptyl)-1,3,5-triazine (calibrant)
PFTBA	Perfluorotributylamine (calibrant)
Quad	Quadrupole mass filter
RF	Radio frequency
RFPA	Radio frequency power amplifier
SS	Stainless steel
Torr	Unit of pressure, 1 mm Hg
Turbo	Turbomolecular (pump)
WUI	Web user interface
XTR	EI Extractor source



## The 5977B Series MSD

The 5977B Series MSD is a stand-alone capillary GC detector.

The MSD features:

- GC Compatibility includes the Agilent 7890 Series GC and the Agilent 7820 GC
- WUI for locally monitoring and operating the MSD
- A turbo vacuum pump with one of four different foreline pumps or a diffusion vacuum pump with a Pfeiffer DUO 2.5 foreline pump
- Three different types of independently heated MSD EI sources available: standard source in both stainless steel and inert material, and an XTR source.
- A HES
- Inert ion sources available
- Field upgradeable to CI (PCI/NCI) modes that add a CI source, reagent gas flow controller and plumbing, and CI tuning calibration
- Independently MSD heated hyperbolic Quad
- HED EM detector
- Independently GC heated GC/MSD interface
- DIP capability (3rd party).

## Vacuum capability

**Table 3** 5977B Series MSD features

Feature		
High vacuum pump	Diffusion	Turbo
Optimal He column flow mL/min	1	1 to 2
Maximum recommended gas flow mL/min <sup>†</sup>	1.5	4
Maximum gas flow, mL/min <sup>*</sup>	2	6.5
Max column id	0.25 mm (30 m)	0.53 mm (30 m)
CI capability <sup>‡</sup>	No	Yes
Foreline pumps available	Pfeiffer Duo 2.5	Pfeiffer Duo 2.5, MVP-070-3, MVP-070-3C, IDP3 24V

<sup>†</sup> Total gas flow into the MSD: column flow plus reagent gas flow (if applicable). Based on helium gas use. For other gases the maximum flow will vary.

<sup>\*</sup> Expect degradation of spectral performance and sensitivity.

<sup>‡</sup> Turbo pump models are field upgradeable to CI.

## Physical description

The 5977B Series MSD housing is approximately 41 cm high, 30 cm wide, and 54 cm deep. The weight is 39 kg for the DP models, and 46 kg for the EI/CI turbo pump mainframe. The standard foreline (roughing) pump weighs an additional 11 kg (standard pump), and the dry foreline pump weighs 16 kg. The foreline pump is usually located on the floor behind the MSD.

The basic components of the instrument are the:

- Frame/cover assemblies
- Vacuum system
- GC interface
- Electronics
- Analyzer

## Front Panel LED

The front panel LED allows the operator to monitor the MSD. The LED displays the instrument status with color codes and patterns. (See [“Local User Interface, Power Switch, and Front Panel LED”](#) on page 200.)

## Vacuum gauge

The 5977B Series MSD may be equipped with an ion vacuum gauge. The Agilent MassHunter GC/MS Acquisition software can be used to read the pressure (high vacuum) in the vacuum manifold.

The gauge is **required** for CI operation.

## MSD Hardware Description

Figure 1 is an overview of a typical GC/MSD system.

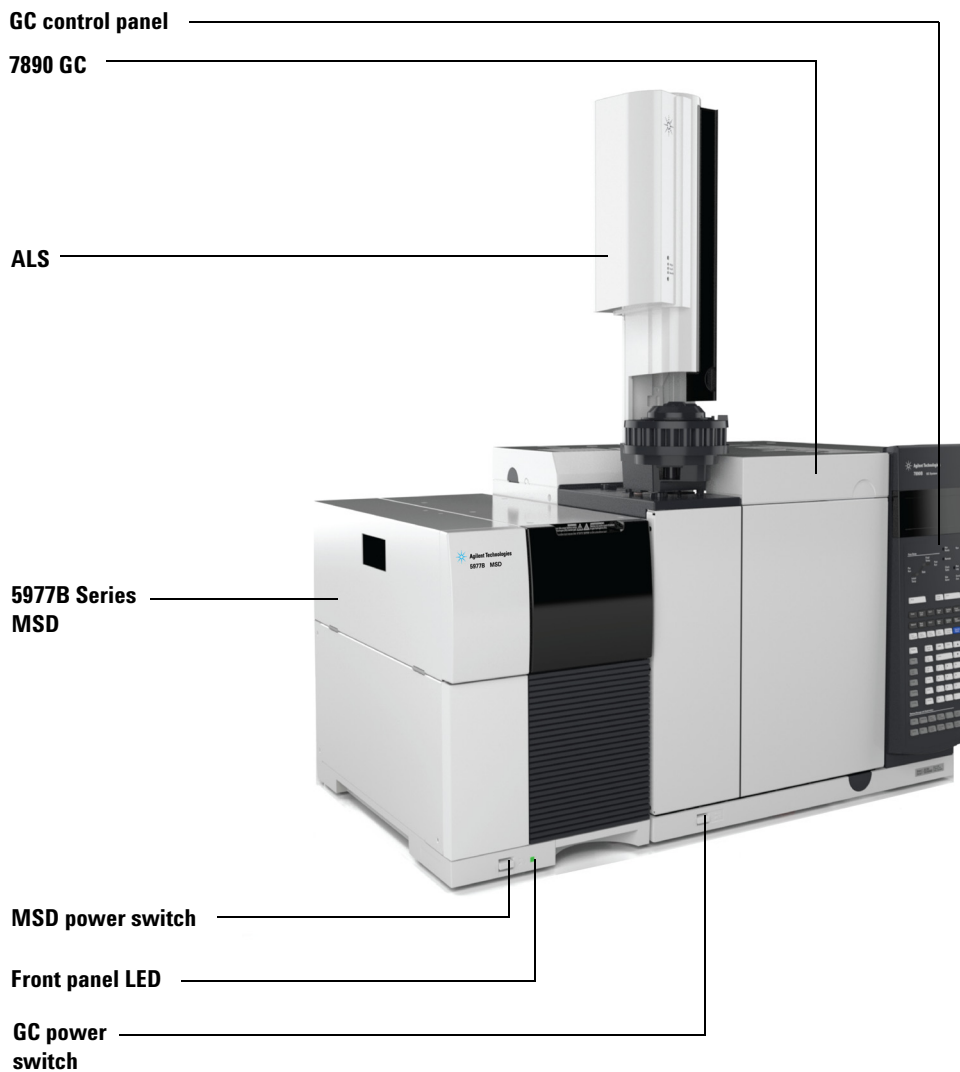

Figure 1 Agilent 5977B Series GC/MS system

## EI systems

EI systems ionize sample molecules by bombarding them with electrons. The ions, including fragments, are drawn into the quadrupole analyzer where they are separated by their mass-to-charge ( $m/z$ ) ratios and detected.

There are four types of EI sources available: the standard EI source, which is available in SS or inert material, the EI XTR source, and the HES.

## CI systems

CI systems use a reagent gas as an intermediate between the electrons and the sample. CI is more gentle than direct electron bombardment.

The CI hardware allows the 5977B Series MSD to produce high-quality, classical CI spectra, which include molecular adduct ions. A variety of reagent gases can be used.

In this manual, the term CI MSD refers to the upgraded G7077B, G7078B, or the upgraded G7079B. It also applies, unless otherwise specified, to the flow modules for these instruments.

The 5977B Series GC/MS CI system adds the following to the 5977B Series MSD:

- An EI/CI GC/MSD interface
- A reagent gas flow control module
- A bipolar HED power supply for PCI and NCI operation

A required methane/isobutane gas purifier is provided. It removes oxygen, water, hydrocarbons, and sulfur compounds.

A high vacuum gauge controller (G3397B) required for CI MSD is also recommended for EI.

The MSD CI system has been optimized to achieve the relatively high source pressure required for CI, while still maintaining a high vacuum in the quadrupole and detector. Special seals along the flow path of the reagent gas and very small openings in the ion source keep the source gases in the ionization volume long enough for the appropriate reactions to occur.

The CI interface has special plumbing for reagent gas.

## **Changing modes**

Switching back and forth between CI and EI sources takes less than an hour, although a 1- to 2-hour wait is required to purge the reagent gas lines and bake out water and other contaminants. Switching from PCI to NCI requires about 2 hours for the ion source to cool.

## Important Safety Warnings

There are several important safety notices to keep in mind when using the MSD.

### Many internal parts of the MSD carry dangerous voltages

If the MSD is connected to a power source, even if the power switch is off, potentially dangerous voltages exist on:

- The wiring between the MSD power cord and the AC power supply, the AC power supply itself, and the wiring from the AC power supply to the power switch.

With the power switch on, potentially dangerous voltages also exist on:

- All electronics boards in the instrument
- The internal wires and cables connected to these boards
- The wires for any heater (oven, detector, inlet, or valve box)

#### **WARNING**

**All these parts are shielded by covers. With the covers in place, it should be difficult to accidentally make contact with dangerous voltages. Unless specifically instructed to, never remove a cover unless the detector, inlet, or oven are turned off.**

---

#### **WARNING**

**If the power cord insulation is frayed or worn, the cord must be replaced. Contact your Agilent service representative.**

---

### Electrostatic discharge is a threat to MSD electronics

The printed circuit boards in the MSD can be damaged by electrostatic discharge. Do not touch any of the boards unless it is absolutely necessary. If you must handle them, wear a grounded wrist strap and take other antistatic precautions. Wear a grounded wrist strap any time you remove the MSD right side cover.

## Many parts are dangerously hot

Many parts of the GC/MSD operate at temperatures high enough to cause serious burns. These parts include, but are not limited to the:

- GC inlets
- GC oven and its contents, including the column nuts attaching the column to a GC inlet, GC/MS interface, or GC detector
- GC detector
- GC valve box
- Foreline pump
- Heated MSD ion source, interface, and quadrupole

Always cool these areas of the system to room temperature before working on them. They will cool faster if you first set the temperature of the heated zone to room temperature. Turn the zone off after it has reached the setpoint. If you must perform maintenance on hot parts, use a wrench and wear gloves. Whenever possible, cool the part of the instrument that you will be maintaining before you begin working on it.

### **WARNING**

**Be careful when working behind the instrument. During cooldown cycles, the GC emits hot exhaust which can cause burns.**

---

### **WARNING**

**The insulation around the inlets, detectors, valve box, and the insulation cups is made of refractory ceramic fibers. To avoid inhaling fiber particles, we recommend the following safety procedures: ventilate your work area; wear long sleeves, gloves, safety glasses, and a disposable dust/mist respirator; dispose of insulation in a sealed plastic bag; wash your hands with mild soap and cold water after handling the insulation.**

---

## The oil pan under the standard foreline pump can be a fire hazard

Oily rags, paper towels, and similar absorbents in the oil pan could ignite and damage the pump and other parts of the MSD.



**WARNING**

**Combustible materials (or flammable/nonflammable wicking material) placed under, over, or around the foreline (roughing) pump constitutes a fire hazard. Keep the pan clean, but do not leave absorbent material such as paper towels in it.**

---

## Hydrogen Safety

**WARNING**

The use of hydrogen as a GC carrier gas is potentially dangerous.

---

**WARNING**

When using hydrogen (H<sub>2</sub>) as the carrier gas or fuel gas, be aware that hydrogen can flow into the GC oven and create an explosion hazard. Therefore, ensure that the supply is turned off until all connections are made, and that the inlet and detector column fittings are either connected to a column or capped at all times when hydrogen is supplied to the instrument.

Hydrogen is flammable. Leaks, when confined in an enclosed space, may create a fire or explosion hazard. In any application using hydrogen, leak test all connections, lines, and valves before operating the instrument. Always turn off the hydrogen supply at its source before working on the instrument.

---

Hydrogen is a commonly used GC carrier gas. Hydrogen is potentially explosive and has other dangerous characteristics.

- Hydrogen is combustible over a wide range of concentrations. At atmospheric pressure, hydrogen is combustible at concentrations from 4% to 74.2% by volume.
- Hydrogen has the highest burning velocity of any gas.
- Hydrogen has a very low ignition energy.
- Hydrogen that is allowed to expand rapidly from high pressure can self-ignite.
- Hydrogen burns with a nonluminous flame which can be invisible under bright light.

Additional information can be found in the *Hydrogen Safety Guide* which is included on this Agilent 5977B Series MSD User Information media.

## Dangers unique to GC/MSD operation

Hydrogen presents a number of dangers. Some are general, others are unique to GC or GC/MSD operation. Dangers include, but are not limited to:

- Combustion of leaking hydrogen
- Combustion due to rapid expansion of hydrogen from a high-pressure cylinder
- Accumulation of hydrogen in the GC oven and subsequent combustion (see your GC documentation and the label on the top edge of the GC oven door)
- Accumulation of hydrogen in the MSD and subsequent combustion

## Hydrogen accumulation in an MSD

### WARNING

**The MSD cannot detect leaks in inlet or detector gas streams. For this reason, it is vital that column fittings should always be either connected to a column, or have a cap or plug installed.**

All users should be aware of the mechanisms by which hydrogen can accumulate and know what precautions to take if they know or suspect that hydrogen has accumulated. (See [Table 4](#).) Note that these mechanisms apply to *all* mass spectrometers, including the MSD.

**Table 4** Hydrogen accumulation mechanisms

Mechanism	Results
Mass spectrometer turned off	A mass spectrometer can be shut down deliberately. It can also be shut down accidentally by an internal or external failure. There is a safety feature that will shutdown the flow of carrier gas in the event of an MSD foreline pump shutdown. However, if this feature fails, hydrogen may slowly accumulate in the mass spectrometer.

**Table 4** Hydrogen accumulation mechanisms (continued)

Mechanism	Results
Mass spectrometer automated shutoff valves closed	Some mass spectrometers are equipped with automated shutoff valves. In these instruments, deliberate operator action or various failures can cause the shutoff valves to close. Closing the shutoff valves does not shut off the flow of carrier gas. As a result, hydrogen may slowly accumulate in the mass spectrometer.
Mass spectrometer manual shutoff valves closed	Some mass spectrometers are equipped with manual shutoff valves. In these instruments, the operator can close the shutoff valves. Closing the shutoff valves does not shut off the flow of carrier gas. As a result, hydrogen may slowly accumulate in the mass spectrometer.
GC off	A GC can be shut down deliberately. It can also be shut down accidentally by an internal or external failure. Different GCs react in different ways. If a 7890 GC equipped with Electronic Pressure Control (EPC) is shut off, the EPC stops the flow of carrier gas. If the carrier flow is <b>not</b> under EPC control, the flow increases to its maximum. This flow may be more than some mass spectrometers can pump away, resulting in the accumulation of hydrogen in the mass spectrometer. If the mass spectrometer is shut off at the same time, the accumulation can be fairly rapid.
Power failure	If the power fails, both the GC and mass spectrometer shut down. The carrier gas, however, is not necessarily shut down. As described previously, in some GCs a power failure may cause the carrier gas flow to be set to maximum. As a result, hydrogen may accumulate in the mass spectrometer.

**WARNING**

Once hydrogen has accumulated in a mass spectrometer, extreme caution must be used when removing it. Incorrect startup of a mass spectrometer filled with hydrogen can cause an explosion.

---

**WARNING**

After a power failure, the mass spectrometer may start up and begin the pumpdown process by itself. This does not guarantee that all hydrogen has been removed from the system, or that the explosion hazard has been removed.

---

## Precautions

Take the following precautions when operating a GC/MSD system with hydrogen carrier gas.

### Equipment precaution

You **MUST** ensure the front side-plate thumbscrew is fastened finger-tight. Do not overtighten the thumbscrew; it can cause air leaks.

**WARNING**

**Failure to secure your MSD as described above greatly increases the chance of personal injury in the event of an explosion.**

---

You must remove the analyzer window cover on the front of a 5977B MSD. In the unlikely event of an explosion, this cover may dislodge.

### General laboratory precautions

- Avoid leaks in the carrier gas lines. Use leak-checking equipment to periodically check for hydrogen leaks.
- Eliminate from your laboratory as many ignition sources as possible (open flames, devices that can spark, sources of static electricity, etc.).
- Do not allow hydrogen from a high pressure cylinder to vent directly to atmosphere (danger of self-ignition).
- Use a hydrogen generator instead of bottled hydrogen.

### Operating precautions

- Turn off the hydrogen at its source every time you shut down the GC or MSD.
- Turn off the hydrogen at its source every time you vent the MSD (do not heat the capillary column without carrier gas flow).
- Turn off the hydrogen at its source every time shutoff valves in an MSD are closed (do not heat the capillary column without carrier gas flow).
- Turn off the hydrogen at its source if a power failure occurs.
- If a power failure occurs while the GC/MSD system is unattended, even if the system has restarted by itself:
  - 1 Immediately turn off the hydrogen at its source.
  - 2 Turn off the GC.
  - 3 Turn off the MSD, and allow it to cool for 1 hour.
  - 4 Eliminate **all** potential sources of ignition in the room.
  - 5 Open the vacuum manifold of the MSD to atmosphere.
  - 6 Wait at least 10 minutes to allow any hydrogen to dissipate.
  - 7 Start up the GC and MSD as normal.

When using hydrogen, check the system for leaks to prevent possible fire and explosion hazards based on local Environmental Health and Safety (EHS) requirements. Always check for leaks after changing a tank or servicing the gas lines. Always make sure the vent line is vented into a fume hood.

## Safety and Regulatory Certifications

The 5977B Series MSD conforms to the following safety standards:

- Canadian Standards Association (CSA): CAN/CSA-C222 No. 61010-1-04
- CSA/Nationally Recognized Test Laboratory (NRTL): UL 61010-1
- International Electrotechnical Commission (IEC): 61010-1
- EuroNorm (EN): 61010-1

The 5977B Series MSD conforms to the following regulations on Electromagnetic Compatibility (EMC) and Radio Frequency Interference (RFI):

- CISPR 11/EN 55011: Group 1, Class A
- IEC/EN 61326
- AUS/NZ 

This ISM device complies with Canadian ICES-001. Cet appareil ISM est conforme a la norme NMB-001 du Canada.



The 5977B Series MSD is designed and manufactured under a quality system registered to ISO 9001.

The 5977B Series MSD is RoHS compliant.

### Information

The 5977B Series MSD meets the following IEC (International Electro-technical Commission) classifications: Equipment Class I, Laboratory Equipment, Installation Category II, Pollution Degree 2.

This unit has been designed and tested in accordance with recognized safety standards, and is designed for use indoors. If the instrument is used in a manner not specified by the manufacturer, the protection provided by the instrument may be impaired. Whenever the safety protection of the MSD has been compromised, disconnect the unit from all power sources, and secure the unit against unintended operation.

Refer servicing to qualified service personnel. Substituting parts or performing any unauthorized modification to the instrument may result in a safety hazard.

## Symbols

Warnings in the manual or on the instrument must be observed during all phases of operation, service, and repair of this instrument. Failure to comply with these precautions violates safety standards of design and the intended use of the instrument. Agilent Technologies assumes no liability for the customer's failure to comply with these requirements.

See accompanying instructions for more information.



Indicates a hot surface.



Indicates hazardous voltages.



Indicates earth (ground) terminal.



Indicates potential explosion hazard.



Indicates radioactivity hazard.



Indicates electrostatic discharge hazard.



Indicates that you must not discard this electrical/electronic product in domestic household waste.





## Electromagnetic compatibility

This device complies with the requirements of CISPR 11. Operation is subject to the following two conditions:

- This device may not cause harmful interference.
- This device must accept any interference received, including interference that may cause undesired operation.

If this equipment does cause harmful interference to radio or television reception, which can be determined by turning the equipment off and on, the user is encouraged to try one or more of the following measures:

- Relocate the radio or antenna.
- Move the device away from the radio or television.
- Plug the device into a different electrical outlet, so that the device and the radio or television are on separate electrical circuits.
- Make sure that all peripheral devices are also certified.
- Make sure that appropriate cables are used to connect the device to peripheral equipment.
- Consult your equipment dealer, Agilent Technologies, or an experienced technician for assistance.

Changes or modifications not expressly approved by Agilent Technologies could void the user's authority to operate the equipment.

## Sound emission declaration

### Sound pressure

Sound pressure  $L_p < 70$  dB according to EN 27779:1991.

### Schalldruckpegel

Schalldruckpegel  $L_p < 70$  dB am nach EN 27779:1991.

## **Cleaning/Recycling the Product**

To clean the unit, disconnect the power and wipe down with a damp, lint-free cloth. For recycling, contact your local Agilent sales office.

## **Moving or Storing the MSD**

The best way to keep your MSD functioning properly is to keep it pumped down and hot, with carrier gas flow. If you plan to move or store your MSD, a few additional precautions are required. The MSD must remain upright at all times; this requires special caution when moving. The MSD should not be left vented to the atmosphere for long periods.

## To Replace the Primary Fuses

### Materials needed

- Fuse, T12.5A, 250 V (2110-1398) – 2 required
- Screwdriver, flat-blade (8730-0002)

The most likely cause of failure of the primary fuses is a problem with the foreline pump. If the primary fuses in your MSD fail, check the foreline pump.

### Procedure

- 1 Vent the MSD, and unplug the power cord from the electrical outlet.

If one of the primary fuses has failed, the MSD will already be off, but for safety you should switch off the MSD and unplug the power cord. It is not necessary to allow air into the analyzer chamber.

---

**WARNING**

**Never replace the primary fuses while the MSD is connected to a power source.**

---

**WARNING**

**If you are using hydrogen as a GC carrier gas, a power failure may allow it to accumulate in the analyzer chamber. In that case, further precautions are required. (See “Hydrogen Safety” on page 22.)**

- 2 Turn one of the fuse holders counterclockwise until it pops out. The fuse holders are spring loaded. (See [Figure 2](#) on page 32.)
- 3 Remove the old fuse from the fuse holder.
- 4 Install a new fuse in the fuse holder.
- 5 Reinstall the fuse holder.

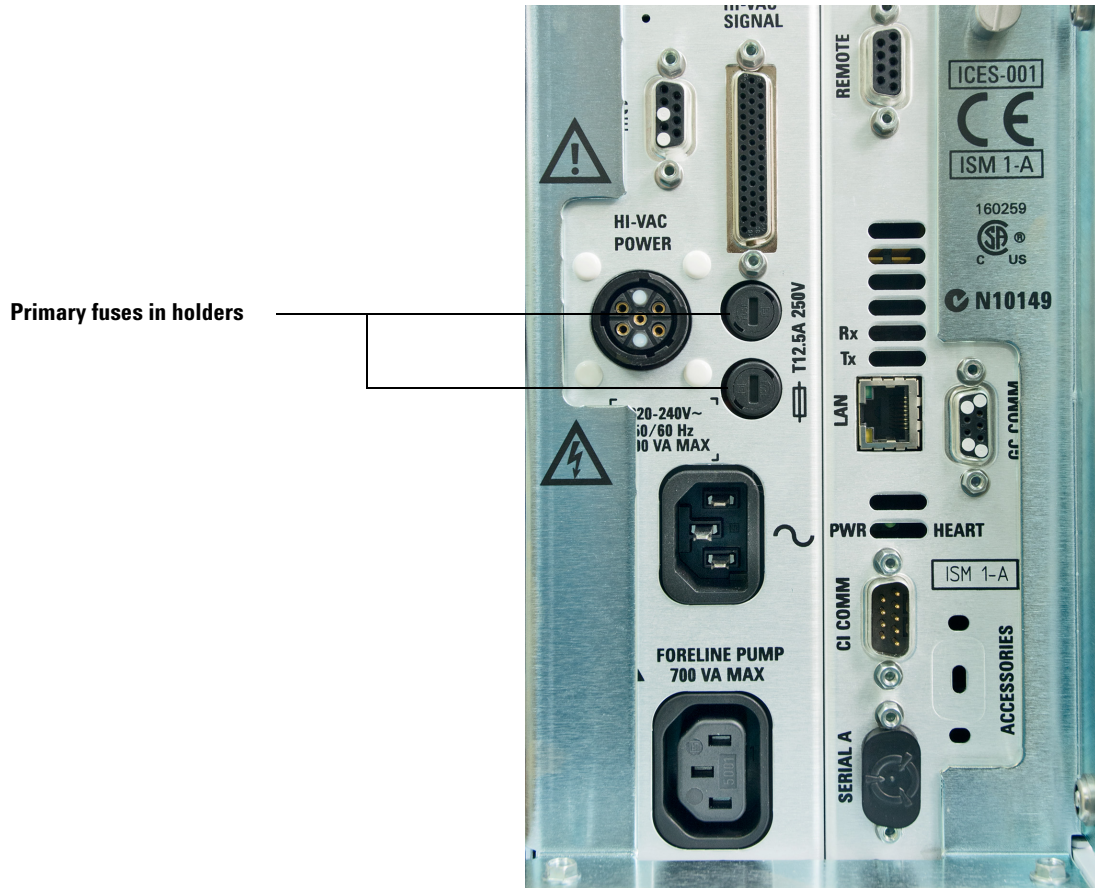
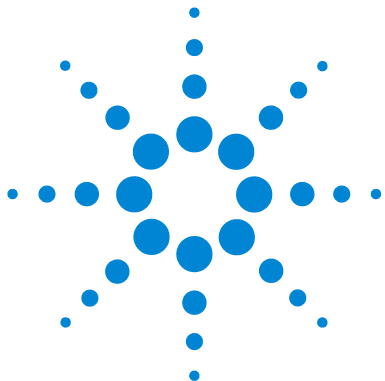

Figure 2 Primary fuses

- 6 Repeat steps 3 through 5 for the other fuse. Always replace both fuses.
- 7 Reconnect the MSD power cord to the electrical outlet.
- 8 Pump down the MSD.



## 2 General Troubleshooting

Front Panel Instrument Status LED	34
Troubleshooting Tips and Tricks	35
General Symptoms	36
Chromatographic Symptoms	38
Mass Spectral Symptoms	43
Pressure Symptoms	47
Temperature Symptoms	50
Error Messages	52
Air Leaks	58
Contamination	59

This chapter discusses how to identify the symptoms and causes of the most common problems experienced by users with your MSD. Help with CI-specific problems is found later in this manual. (See [Chapter 3](#), “CI Troubleshooting,” starting on page 61.) For each symptom, one or more possible causes are listed. In general, the causes listed first are the most likely causes **or** the easiest to check and correct.

This chapter does not include corrective actions for the possible causes listed. Some of the corrective actions required may be dangerous if performed incorrectly. Do not attempt any corrective actions unless you are sure of the correct procedure and the dangers involved. See the *Troubleshooting* section in the online help and the other chapters in this manual for more information.

If the material in this chapter and in the online help does not help you diagnose your problem, contact your Agilent Technologies service representative.



## Front Panel Instrument Status LED

Through the front panel instrument status LED, the operator can view the current status of the instrument using color codes and LED on/off timing. (See [Table 5](#).)

**Table 5** Front panel Instrument Status LED codes

<b>Instrument status</b>	<b>LED code</b>
Ready	Solid green
Acquiring data	Blinking green (<2 sec)
Not ready	Solid yellow
JetClean <b>Acquire &amp; Clean</b> operation	Blinking magenta
JetClean <b>Clean Only</b> operation	Solid magenta
Ready and not connected to DS	Solid blue
Start up (prior to FW load)	Blinking red (<2 sec)
Fault	Solid red

## Troubleshooting Tips and Tricks

### **Rule 1: Look for what has been changed.**

Many problems are introduced accidentally by human actions. Every time any system is disturbed, there is a chance of introducing a new problem.

- If the MSD was just pumped down after maintenance, suspect air leaks or incorrect assembly.
- If carrier gas or helium gas purifier were just changed, suspect leaks or contaminated or incorrect gas.
- If the GC column was just replaced, suspect air leaks or contaminated or bleeding column.

### **Rule 2: If complex is not working, go back to simple.**

A complex task is not only more difficult to perform but also more difficult to troubleshoot. If you are having trouble detecting your sample, verify that autotune is successful.

### **Rule 3: Divide and conquer.**

This technique is known as half-split troubleshooting. If you can isolate the problem to only part of the system, it is much easier to locate.

- To determine whether an air leak is in the GC or the MSD, you can vent the MSD, remove the column, and install the blank interface ferrule. If the leak goes away, it was in the GC.

### General Symptoms

This section describes symptoms you might observe when first turning on the GC/MSD system, and their possible causes. Any of these symptoms would prevent operation of the system.

#### GC does not turn on

Nothing happens when the GC is switched on. The GC fans do not turn on, and the keypad display does not light.

- Disconnected GC power cord
- No voltage or incorrect voltage at the electrical outlet
- Failed fuse in the GC
- GC power supply is not working correctly

#### MSD does not turn on

Nothing happens when the MSD is switched on. The foreline pump does not start. The cooling fan for the high vacuum pump does not turn on.

- Disconnected MSD power cord
- No voltage or incorrect voltage at the electrical outlet
- Failed primary fuses
- MSD electronics are not working correctly

#### Foreline pump is not operating

The MSD is receiving power (the fan is operating), but the foreline pump is not operating.

- Large air leak (usually the analyzer door open) has caused pumpdown failure. (See [“Pumpdown failure shutdown”](#) on page 146.) You must power cycle the MSD to recover from this state.
- Disconnected foreline pump power cord
- Malfunctioning foreline pump
- Check power switch on foreline pump



## **MSD turns on, but then the foreline pump shuts off**

MSDs will shut down both the foreline pump and the high vacuum pump if the system fails to pump down correctly. This is usually because of a large air leak: either the sideplate has not sealed correctly, or the vent valve is still open. This feature helps prevent the foreline pump from sucking air through the system, which can damage the analyzer and pump. (See [“Pumpdown failure shutdown”](#) on page 146.) You must power cycle the MSD to recover from this state.

### Chromatographic Symptoms

These are symptoms you may observe in the chromatograms generated by data acquisition. In general, these symptoms do not prevent you from operating your GC/MSD system. They indicate, however, that the data you are acquiring may not be the best data obtainable. These symptoms can be caused by instrument malfunctions, but are more likely caused by incorrect chromatographic technique.

The following symptoms also apply to mass spectral data:

- If sensitivity is low
- If repeatability is poor

#### No peaks

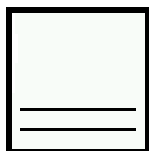

If an analysis shows no chromatographic peaks, only a flat baseline or minor noise, run one of the automated tune programs. If the MSD passes tune, the problem is most likely related to the GC. If the MSD does not pass tune, the problem is most likely in the MSD.

#### Passes tune

- Incorrect sample concentration
- No analytes present
- Syringe missing from the ALS, or not installed correctly
- Injection accidentally made in split mode instead of splitless mode
- Empty or almost empty sample vial
- Dirty GC inlet
- Leaking GC inlet<sup>†</sup>
- Loose column nut at the GC inlet<sup>†</sup>

<sup>†</sup> This could cause a fault condition in the GC that would prevent the GC from operating.

#### Does not pass tune

- Calibration vial is empty
- Excessive foreline or analyzer chamber pressure

- Very dirty ion source
- Calibration valve is not working correctly
- Bad signal cable connection
- Filament has failed, or is not connected correctly
- Bad ion source wiring connection
- Bad detector wiring connection
- Failed electron multiplier horn

### Peaks are tailing

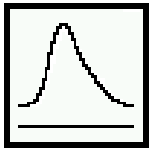

- Active sites in the sample path
- Injection is too large
- Incorrect GC inlet temperature
- Insufficient column flow
- GC/MSD interface temperature is too low
- Ion source temperature is too low

### Peaks are fronting

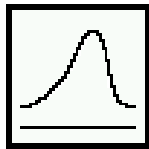

- Column film thickness mismatched with analyte concentration (column overload)
- Initial oven temperature is too low
- Active sites in the sample path
- Injection is too large
- GC inlet pressure too high
- Insufficient column flow

### Peaks have flat tops

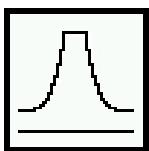

- Insufficient solvent delay
- Incorrect scale on the display
- Injection is too large
- EMV is too high
- Gain is too high

### Peaks have split tops

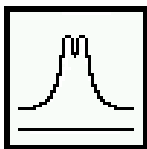

- Bad injection technique
- Injection is too large

### Baseline is rising

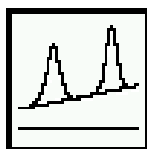

- Column bleed
- Other contamination

### Baseline is high

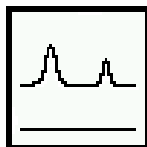

- Column bleed
- Other contamination
- EMV is too high

### Baseline is falling

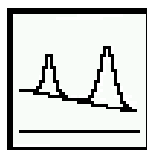

A falling baseline indicates contamination is being swept away. Wait until the baseline reaches an acceptable level. Common causes include:

- Residual water air and water from a recent venting
- Column bleed
- Septum bleed
- Splitless injection time too long (inlet is not properly swept, resulting in excess solvent on the column and slow solvent decay)

### Baseline wanders

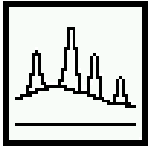

- Insufficient carrier gas supply pressure<sup>†</sup>
- Malfunctioning flow or pressure regulator<sup>†</sup>
- Intermittent leak in the GC inlet<sup>†</sup>

<sup>†</sup> These could cause a fault condition in the GC that would prevent the GC from operating.

### Retention times for all peaks drift – shorter

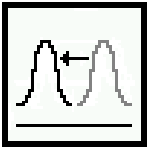

- Column has been shortened
- Initial oven temperature was increased
- Column is getting old

### Retention times for all peaks drift – longer

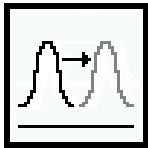

- Column flow has been reduced
- Initial oven temperature was decreased
- Active sites in the sample path
- Leaks in the GC inlet<sup>†</sup>

<sup>†</sup> This could cause a fault condition in the GC that would prevent the GC from operating.

### Poor sensitivity

- Incorrect tuning
- Tune file that does not match the type of analysis
- Repeller voltage is too low
- Incorrect temperatures (oven, GC/MSD interface, ion source, or mass filter)
- Incorrect sample concentration
- Leaking GC inlet<sup>†</sup>
- Dirty GC inlet
- Incorrect split ratio
- Purge off time in splitless mode is too short
- Excessive pressure in the MSD
- Dirty ion source
- Air leak
- Poor filament operation
- Detector (HED electron multiplier) is not working correctly
- Incorrect mass filter polarity

<sup>†</sup> This could cause a fault condition in the GC that would prevent the GC from operating.

### Poor repeatability

- Dirty syringe needle
- Dirty GC inlet
- Leaking GC inlet<sup>†</sup>
- Injection is too large
- Loose column connections
- Variations in pressure, column flow, and temperature
- Dirty ion source
- Loose connections in the analyzer
- Ground loops

<sup>†</sup> This could cause a fault condition in the GC that would prevent the GC from operating.

## Mass Spectral Symptoms

This section describes symptoms you might observe in mass spectra. Some of these symptoms will appear in the mass spectra of samples. Others you will observe only in a tune report. Some of these symptoms have causes that can be corrected by the operator. Others, however, require service by an Agilent Technologies service representative.

The following symptoms listed under Chromatic symptoms also apply to mass spectra:

- If sensitivity is low
- If repeatability is poor

### No peaks

- Ion source cables not connected
- Bad connections to or from the detector
- HED power supply output cable has failed
- Other electronics failure
- Incorrect tune file (inappropriate parameters)

### Isotopes are missing or isotope ratios are incorrect

- Peaks are too wide or too narrow
- Scan speed is too high (scan mode)
- Dwell time is too short (SIM mode)
- EMV is too high
- Repeller voltage is too high
- High background
- Dirty ion source

### High background

- Pressure in the analyzer chamber is too high
- Air leak
- Contamination

### High abundances at $m/z$ H<sub>2</sub>O [18], N<sub>2</sub> [28], O<sub>2</sub> [32], and CO<sub>2</sub> [44] or at $m/z$ 14 and 16

- System was recently vented (residual air and water)
- Air leak, large peaks at  $m/z$  14 and 16 are symptomatic of especially large leaks.

### Mass assignments are incorrect

Small shape changes at the top of the mass peaks can cause 0.1  $m/z$  shifts in mass assignments. Shifts greater than 0.2  $m/z$  indicate a possible malfunction.

- MSD has not had enough time to reach thermal equilibrium
- Scan speed is too fast
- Large variations in the temperature of the laboratory
- MSD has not been tuned recently, or at the temperature at which it is operating
- Incorrect tune file (inappropriate parameters)
- No voltage to extractor lens (if using an EI XTR source)

### Peaks have precursors

The tune report lists the size of the precursors for the tune masses. Small precursors are not unusual. If the precursors are unacceptably large for your application, one of the following may be responsible:

- Repeller voltage is too high
- Peaks are too wide
- Incorrect DC polarity on the Quad
- Dirty Quad

### Peak widths are inconsistent

- MSD has not had enough time to reach thermal equilibrium
- Large variations in the temperature of the laboratory
- Incorrect tuning
- Calibration vial(s) empty or almost empty
- Calibration valve(s) not working correctly
- Dirty ion source



- EMIs nearing the end of its useful lifetime
- Ground loop problems

### Relative abundance of $m/z$ 502 is less than 3%

Autotune should give an  $m/z$  502 relative abundance greater than 3%. The relative abundance of  $m/z$  502 can, however, vary a great deal depending on column flow, ion source temperature, and other variables. As long as relative abundance is above 3%, the stability of the relative abundance is more important than the absolute value. If you observe significant changes in the relative abundance of  $m/z$  502 for a fixed set of operating parameters, there may be a problem. The charts in the Agilent MassHunter GC/MS Acquisition software are useful for identifying changes.

Low **relative** abundance of  $m/z$  502 should not be confused with low **absolute** abundances at high masses. Sensitivity at high masses can be excellent even if the relative abundance of  $m/z$  502 is near 3%. If your MSD produces low absolute abundances at high masses, refer to the symptom *High mass sensitivity is poor*.

Tune programs other than autotune have different relative abundance targets. The DFTPP and BFB target tune programs tune the MSD to achieve about a 0.8% ratio of  $m/z$  502/69.

- Tune program/tune file has a different relative abundance target (3% only applies to Autotune)
- Not enough time for the MSD to warm up and pump down
- Analyzer chamber pressure is too high
- Ion source temperature is too high
- Column (carrier gas) flow is too high
- Poor filament operation
- Dirty ion source
- Air leak
- Incorrect DC polarity on the Quad

### Spectra look different from those acquired with other MSDs

Ion ratios are different from those in older models MSDs. This is due to the HED detector, and is normal.

### High mass sensitivity is poor

This refers to a condition where the **absolute** abundance at the upper end of the mass range is poor. Absolute abundance should not be confused with the **relative** abundance (percentage) of  $m/z$  502 to  $m/z$  69. Sensitivity at high masses can be excellent even if the relative abundance of  $m/z$  502 is low.

- Wrong tune program
- Wrong tune file
- Repeller voltage is too low
- Not enough time for the MSD to warm up and pump down
- Analyzer chamber pressure is too high
- Column (carrier gas) flow is too high
- Poor filament operation
- Dirty ion source
- Air leak
- Incorrect DC polarity on the Quad
- No voltage to the extractor lens (is using an EI XTR source)

## Pressure Symptoms

This section describes unusual pressure readings and their possible causes. The symptoms in this section are based on typical pressures. At typical column flow rates (0.1 to 2.0 mL/minute), the foreline pressure will be approximately 20 to 100 mTorr. The analyzer chamber pressure will be approximately  $1 \times 10^{-6}$  to  $1.4 \times 10^{-4}$  Torr. These pressures can vary widely from instrument to instrument so it is very important that you are familiar with the pressures that are typical for your instrument at given carrier gas flows. Also, foreline pressures can only be measured on DP MSDs.

Turbo pumps are controlled according to their speed, and do not have foreline pressure gauges. The analyzer chamber pressures can only be measured if your system is equipped with the optional gauge controller.

### Foreline pressure is too high

If the pressure you observe for a given column flow has increased over time, check the following:

- Column (carrier gas) flow is too high
- Air leak (usually the sideplate is not pushed in or vent valve is open)
- Foreline pump oil level is low or oil is contaminated (standard foreline pump)
- Foreline hose is constricted
- Foreline pump is not working correctly

### Analyzer chamber pressure is too high (EI operation)

If the pressure you observe is above  $1.0 \times 10^{-4}$  Torr, or if the pressure you observe for a given column flow has increased over time, check the following:

- Column (carrier gas) flow is too high
- Air leak
- Foreline pump is not working correctly (see *Foreline pressure is too high*)
- Turbo pump is not working correctly
- DP fluid level is low, or fluid is contaminated

### Foreline pressure is too low

If the pressures you observe are below 20 mTorr, check for the following:

- Column (carrier gas) flow is too low
- Column plugged or crushed by an overtightened nut
- Empty or insufficient carrier gas supply<sup>†</sup>
- Bent or pinched carrier gas tubing<sup>†</sup>
- Foreline gauge is not working correctly

<sup>†</sup> These could create a fault condition in the GC that would prevent the GC from operating.

### Analyzer chamber pressure is too low

If the pressures you observe are below  $1 \times 10^{-6}$  Torr, check for the following:

- Column (carrier gas) flow is too low
- Column plugged or crushed by overtightened nut
- Empty or insufficient carrier gas supply<sup>†</sup>
- Bent or pinched carrier gas tubing<sup>†</sup>

<sup>†</sup> These could create a fault condition in the GC that would prevent the GC from operating.

### Gauge controller displays 9.9+9 and then goes blank

This indicates the pressure in the analyzer chamber is above  $8 \times 10^{-3}$  Torr.

- Solvent peak from an on-column injection
- MSD has not had enough time to pump down
- Excessive foreline pressure
- Vacuum gauge has failed
- Line voltage too low
- Turbo pump is not working correctly
- DP fluid level is low, or fluid is contaminated

### **Power indicator on the gauge controller does not light**

- Unplugged gauge controller power cord
- Incorrect or inadequate line voltage (24 V supply)
- Failed gauge controller fuse

### Temperature Symptoms

The MSD has three heated zones:

- Ion source
- Mass filter
- GC/MSD interface

Each heated zone has a heater and temperature sensor. The ion source and mass filter are powered and controlled by the MSD. The GC/MSD interface is powered and controlled by the GC. For the 7820A Series GC's, the heater is either connected to the rear inlet thermal zone for the single inlet models or connected to the manual valve thermal zone for dual inlet models.

#### Ion source will not heat up

- High vacuum pump is off or has not reached normal operating conditions<sup>†</sup>
- Incorrect temperature setpoint
- Ion source has not had enough time to reach temperature setpoint
- Ion source heater cartridge is not connected<sup>†</sup>
- Ion source temperature sensor is not connected<sup>†</sup>
- Ion source heater failed (burned out or shorted to ground)<sup>†</sup>
- Ion source temperature sensor failed<sup>†</sup>
- Source power cable is not connected to the side board<sup>†</sup>
- MSD electronics are not working correctly

<sup>†</sup> These will cause an error message.

#### Mass filter (quad) heater will not heat up

- High vacuum pump is off or has not reached normal operating conditions<sup>†</sup>
- Incorrect temperature setpoint
- Mass filter has not had enough time to reach temperature setpoint
- Mass filter heater cartridge is not connected<sup>†</sup>
- Mass filter temperature sensor is not connected<sup>†</sup>
- Mass filter heater failed (burned out or shorted to ground)<sup>†</sup>

- Mass filter temperature sensor failed<sup>†</sup>
- Source power cable is not connected to the sideboard<sup>†</sup>
- MSD electronics are not working correctly

<sup>†</sup> These will cause an error message.

### **GC/MSD interface will not heat up**

- Incorrect setpoint(s)
- Setpoint entered in wrong heated zone
- GC/MSD interface has not had enough time to reach temperature setpoint
- GC is off
- GC experienced a fault and needs to be reset<sup>†</sup>
- GC/MSD interface heater/sensor cable is not connected<sup>†</sup>
- GC/MSD heater failed (burned out)<sup>†</sup>
- GC/MSD sensor failed<sup>†</sup>
- GC electronics are not working correctly<sup>†</sup>

<sup>†</sup> These will cause a GC error message. GC error messages are described in the documentation supplied with your GC.

### Error Messages

Sometimes, a problem in your MSD will cause an error message to appear in the Agilent MassHunter GC/MS Acquisition software. Some error messages appear only during tuning. Other messages may appear during tuning or data acquisition.

Some error messages are latched. Latched messages remain active in your DS even if the condition that caused the message has corrected itself. If the cause is removed, these messages can be removed by checking instrument status through the DS.

#### Difficulty in mass filter electronics

- Pressure in the analyzer chamber is too high
- RFPA is not adjusted correctly
- Mass filter (quad) contacts are shorted or otherwise not working correctly
- Mass filter is not working correctly
- MSD electronics are not working correctly

#### Difficulty with the EMsupply

- Large peak, such as the solvent peak, eluted while the analyzer was on
- Pressure in the analyzer chamber is too high
- MSD electronics are not working correctly

#### Difficulty with the fan

If a cooling fan fault occurs, the vacuum control electronics automatically shut off the high vacuum pump, the ion source, and the mass filter heaters. The message: *The system is in vent state* may also appear. It is important to note that even though the high vacuum pump is off, the analyzer chamber may not actually be vented. Precautions to take are listed later in this chapter. (See “[The system is in vent state](#)” on page 56.)

- One of the fans is disconnected
- One of the fans has failed
- MSD electronics are not working correctly



## Difficulty with the HED supply

The only time this error occurs is if the output of the supply cannot get to its destination (the HED).

- Large peak, such as the solvent peak, eluted while the analyzer was on
- Pressure in the analyzer chamber is too high
- Detector is not working correctly
- MSD electronics are not working correctly

## Difficulty with the high vacuum pump

In an MSD equipped with a DP, this indicates the DP became too hot. In an MSD with a turbo pump, this indicates the pump failed to reach 50% of full speed within 7 minutes, or experienced a fault.

You must switch the MSD off and back on to remove this error message. Ensure the DP has cooled, or the turbo pump has slowed down before switching off the MSD. The message will reappear if the underlying problem has not been corrected.

### DP

- Air intakes to the cooling fan are blocked
- High vacuum signal cable is disconnected or not working correctly
- DP temperature sensor is not working correctly
- MSD electronics are not working correctly

### Turbo pump

- Large vacuum leak is preventing the turbo pump from reaching 80% of full speed
- Laboratory temperature is too high (generally above 35 °C)
- Foreline pump is not working correctly
- Turbo pump is not working correctly
- Turbo pump controller is not working correctly
- MSD electronics are not working correctly

### High foreline pressure

- Excessive carrier gas flow (typically > 5 mL/min)
- Excessive solvent volume injected
- Large vacuum leak
- Severely degraded foreline pump oil (standard foreline pump)
- Collapsed or kinked foreline hose
- Foreline pump is not working correctly
- Foreline gauge is not working correctly (DP MSD only)

### Internal MS communication fault

- MSD electronics are not working correctly

### Lens supply fault

- Electrical short in the analyzer
- MSD electronics are not working correctly

### Log amplifier ADC error

- MSD electronics are not working correctly

### Data Acquisition communication error

The GCs and mass spectrometers supported by Agilent MassHunter GC/MS Acquisition software require IPv4 Internet Protocol (IP) addresses. IPv6 IP addresses are not supported. Therefore, any DS computer (PC), router, switch, or hub that handles data packets to and from the instruments must use the IPv4 IP protocol and IPv4 IP addresses for the network interface used for the connections to the GCs and mass spectrometers. If required for other applications, the PC may also have the Ipv6 Protocol configured as an optional configuration for the same network interface card, or a second network interface card.

- LAN cable disconnected
- Incorrect IP configuration
- Incorrect IP address entered for the GC or MSD

## No peaks found

- Emission current was set to 0
- EMV is too low
- Amu gain or offset is too high
- Poor mass axis calibration
- Calibration vial(s) empty or almost empty
- Excessive pressure in the analyzer chamber
- Air leak
- Signal cable is not connected
- Electrical leads to the detector are not connected correctly
- HED power supply output cable failed
- Electrical leads to the ion source are not connected correctly
- Filament shorted to the source body

## Temperature control disabled

- One of the heater fuses has failed
- MSD electronics are not working correctly

## Temperature control fault

This indicates that something has gone wrong with the temperature control of either the ion source or mass filter (quad) heater. The cause can be further isolated by selecting **mp Status/MS TeCtrl Status** in the Tune and Vacuum Control view. One of the following should be displayed as the cause:

- Source temperature sensor is open
- Source temperature sensor is shorted
- Mass filter (quad) temperature sensor is open
- Mass filter (quad) temperature sensor is shorted
- No heater voltage (heater fuse has probably failed)
- Heater voltage is too low

- Temperature zone has timed out (heater failed, bad heater wiring, or loose temperature sensor)
- Problem with the temperature control electronics
- Source heater is open
- Source heater is shorted
- Mass filter heater is open
- Mass filter heater is shorted

### The high vacuum pump is not ready

- DP is on but has not had enough time (10-15 minutes) to reach its normal operating temperature
- Turbo pump is on but has not had enough time (5 minutes) to reach 80% of its normal operating speed
- Level of fluid in the DP is too high
- DP stack is not aligned correctly
- Turbo pump is not working correctly
- MSD electronics are not working correctly

### The system is in standby

This message is triggered by a shutdown signal on the remote start cable. It is usually caused by a GC fault, an ALS fault, or a bad cable connection. Once the cause of the fault is corrected, selecting **MS ON** or checking MSD status should remove the message.

### The system is in vent state

The message says the system is vented. If the fault has just occurred it may still be under vacuum and the DP may still be hot or the turbo pump may still be at high speed. Wait at least 30 minutes after seeing this message before you actually vent the MSD.

#### CAUTION

Venting the MSD too soon after this message appears can damage the turbo pump.

- System was vented on purpose (no problem)
- Fan fault has turned off the high vacuum pump (power cycle the MSD to clear the fault)
- Fuse for the high vacuum pump has failed
- DP heater cartridge has failed
- MSD electronics are not working correctly

### **There is no emission current**

- Filament is not connected properly; try the other filament
- Filament has failed; try the other filament
- MSD electronics are not working correctly

### **There is not enough signal to begin tune**

- Corrupted tune file
- Poor mass axis calibration
- Amu gain or offset is too high
- Calibration vial(s) empty or almost empty
- Excessive pressure in the analyzer chamber
- Air leak
- EMV is too low
- Signal cable is not connected
- Electrical leads to the detector are not connected correctly
- Electrical leads to the ion source are not connected correctly
- Filament shorted to the source body
- Column inserted too far into source

### Air Leaks

Air leaks are a problem for any instrument that requires a vacuum to operate. Leaks are generally caused by vacuum seals that are damaged or not fastened correctly. Symptoms of leaks include:

- Higher than normal analyzer chamber pressure or foreline pressure
- Higher than normal background
- Peaks characteristic of air ( $m/z$  18, 28, 32, and 44 or  $m/z$  14 and 16)
- Poor sensitivity
- Low relative abundance of  $m/z$  502 (this varies with the tune program used)

Leaks can occur in either the GC or the MSD. The most likely point for an air leak is a seal you recently opened.

In the GC, most leaks occur in:

- GC inlet septum
- GC inlet column nut
- Broken or cracked capillary column

Leaks can occur in many more places in the MSD:

- GC/MSD interface column nut
- Side plate O-ring (all the way around)
- Vent valve O-ring
- Calibration valve(s)
- GC/MSD interface O-ring (where the interface attaches to the analyzer chamber)
- Front and rear end plate O-rings
- DP KF seal
- DP baffle adapter O-ring
- Turbo pump O-ring

## Contamination

Contamination is usually identified by excessive background in the mass spectra. It can come from the GC or from the MSD. The source of the contamination can sometimes be determined by identifying the contaminants. Some contaminants are much more likely to originate in the GC. Others are more likely to originate in the MSD.

Contamination originating in the GC typically comes from one of these sources:

- Column or septum bleed
- Dirty GC inlet
- GC inlet liner
- Contaminated syringe
- Poor quality carrier gas
- Dirty carrier gas tubing
- Fingerprints (improper handling of clean parts)

Contamination originating in the MSD typically comes from one of the following sources:

- Air leak
- Cleaning solvents and materials
- DP fluid
- Foreline pump oil (standard foreline pump)
- Fingerprints (improper handling of clean parts)

[Table 6](#) on page 60 lists some of the more common contaminants, the ions characteristic of those contaminants, and the likely sources of those contaminants.

## 2 General Troubleshooting

**Table 6** Common contaminants

Ions ( <i>m/z</i> )	Compound	Possible source
18, 28, 32, 44 or 14, 16	H <sub>2</sub> O, N <sub>2</sub> , O <sub>2</sub> , CO <sub>2</sub> or N, O	Residual air and water, air leaks, outgassing from Vespel ferrules
31, 51, 69, 100, 119, 131, 169, 181, 214, 219, 264, 376, 414, 426, 464, 502, 576, 614	PFTBA and related ions	PFTBA (tuning compound)
31	Methanol	Cleaning solvent
43, 58	Acetone	Cleaning solvent
78	Benzene	Cleaning solvent
91, 92	Toluene or xylene	Cleaning solvent
105, 106	Xylene	Cleaning solvent
151, 153	Trichloroethane	Cleaning solvent
69	Foreline pump oil or PFTBA	Foreline pump oil vapor or calibration valve leak
73, 147, 207, 221, 281, 295, 355, 429	Dimethylpolysiloxane	Septum bleed or methyl silicone column bleed
77, 94, 115, 141, 168, 170, 262, 354, 446	DP fluid and related ions	DP fluid
149	Plasticizer (phthalates)	Vacuum seals (O-rings) damaged by high temperatures, vinyl gloves
Peaks spaced 14 <i>m/z</i> apart	Hydrocarbons	Fingerprints, foreline pump oil



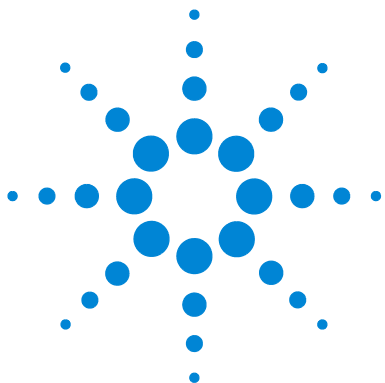

## 3 CI Troubleshooting

Common CI-Specific Problems	62
Troubleshooting Tips and Tricks	63
Air Leaks	64
Pressure-Related Symptoms	68
Signal-Related Symptoms	72
Tuning-Related Symptoms	81

This chapter outlines troubleshooting 5977B Series MSDs equipped with the CI source. Most of the troubleshooting information in the previous chapter also applies to CI MSDs.



## Common CI-Specific Problems

Because of the added complexity of the parts required for CI, there are many potential problems added. The greatest number of, and most serious problems with CI are associated with leaks or contamination in the reagent gas introduction system. NCI is especially sensitive to the presence of air; small leaks that cause no problems in PCI can destroy NCI sensitivity.

As with EI, if the MSD tunes well and no air leak is present, sample sensitivity problems should be addressed by GC inlet maintenance first.

- Wrong reagent gas
- Reagent gas not hooked up or hooked up to wrong reagent gas inlet port
- Wrong ions entered in tune file
- Wrong tune file selected
- Not enough bakeout time has elapsed since vent (background is too high)
- Wrong column positioning (extending > 2 mm past tip of interface)
- Interface tip seal not installed
- EI source installed in CI mode
- EI filament or other EI source parts in CI source
- Air leaks in reagent gas flow path
- CI filament has stretched and sagged:
  - High EMV
  - Linear (no inflection point) electron energy (EIEnrgy) ramp

## Troubleshooting Tips and Tricks

### Rule 1: Look for what has been changed.

Many problems are introduced accidentally by human actions. Every time any system is disturbed, there is a chance of introducing a new problem.

- If the MSD was just pumped down after maintenance, suspect air leaks or incorrect assembly.
- If the reagent gas bottle or gas purifier were just changed, suspect leaks or contaminated or incorrect gas.
- If the GC column was just replaced, suspect air leaks or contaminated or bleeding column.
- If you have just switched ion polarity or reagent gas, suspect the tune file you have loaded in memory. Is it the appropriate file for your mode of operation?

### Rule 2: If complex is not working, go back to simple.

A complex task is not only more difficult to perform, but also more difficult to troubleshoot as well. For example, CI requires more parts to work correctly than EI does.

- If you are having trouble with NCI, verify that PCI still works.
- If you are having trouble with other reagent gases, verify that methane still works.
- If you are having trouble with CI, verify that EI still works.

### Rule 3: Divide and conquer.

This technique is known as half-split troubleshooting. If you can isolate the problem to only part of the system, it is much easier to locate.

- To isolate an air leak, select **Shutoff valve**. If the abundance of  $m/z$  32 decreases, the problem is not in the flow module.

## Air Leaks

### How do I know if I have an air leak?

**Large** air leaks can be detected by vacuum symptoms: loud gurgling noise from the foreline pump, inability of the turbo pump to reach 95% speed, or, in the case of smaller leaks, high pressure readings on the high vacuum gauge controller.

The MFC is calibrated for methane, and the high vacuum gauge controller is calibrated for nitrogen, so measurements are not accurate in absolute terms.

Familiarize yourself with the measurements on **your** system under operating conditions. Watch for **changes** that may indicate a vacuum or gas flow problem.

**Always** look for small air leaks when setting up methane flow. Run the **methane** pretune, starting with a good PCI tune file. (Figure 3 on page 65.) The abundance of  $m/z$  19 (protonated water) should be less than 50% of  $m/z$  17 for acceptable PCI performance. For NCI, the abundance of  $m/z$  19 (protonated water) should be less than 25% that of  $m/z$  17. If the MSD was just pumped down, look for the abundance of  $m/z$  19 to be decreasing.

There should not be any peak visible at  $m/z$  32 ( $O_2$ ). This almost always indicates an air leak.

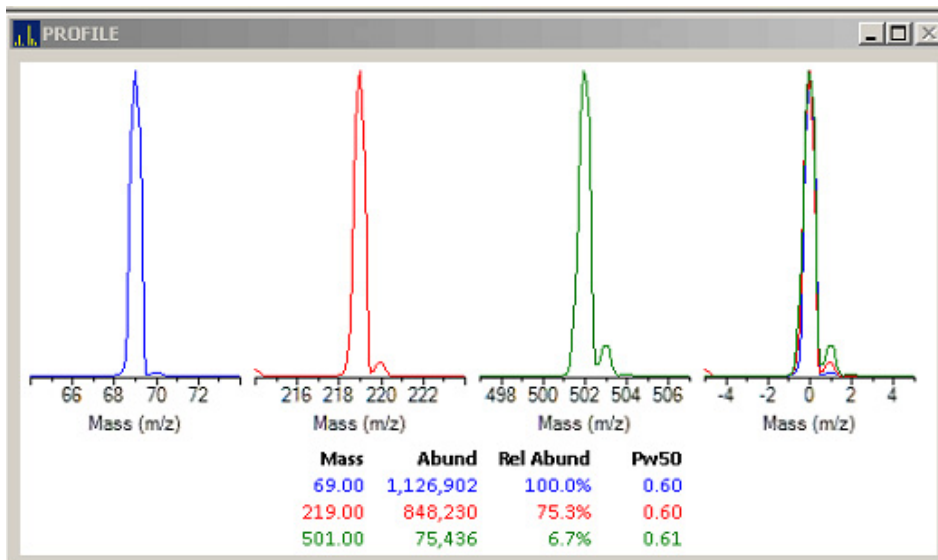

**Figure 3** Looking for air leaks

## Special NCI notes

Since NCI is so extremely sensitive, air leaks that are not detectable in EI or PCI can cause sensitivity problems in NCI. To check for this kind of air leak in NCI, inject OFN. The base peak should be at  $m/z$  272. If the abundance of  $m/z$  238 is much greater than that of  $m/z$  272, you have an air leak.

## How do I find the air leak?

- 1 Look for the last seal that was disturbed. (See [Figure 4](#) on page 67 and [Table 7](#) on page 67.)
  - If you just pumped down the MSD, press on the sideplate to check for proper seal. Poor alignment between the analyzer and the GC/MSD interface seal can prevent the sideplate from sealing.
  - If you just replaced the reagent gas bottle or gas purifier, check the fittings you just opened and refastened.

### 3 CI Troubleshooting

- 2 Check for tightness of seals at GC inlet and interface column nuts. Ferrules for capillary columns often loosen after several heat cycles. Do not overtighten the interface nut.
- 3 If any of the fittings *inside* the flow module (VCR fittings) were loosened and then retightened, the gasket must be replaced. These gaskets are good for one use only.

#### CAUTION

Do not loosen the nuts on any VCR fittings unless you intend to replace the gaskets. Otherwise, you will create an air leak.

---

- 4 Remember that most small air leaks visible in CI mode are located in either the carrier gas or reagent gas flow paths. Leaks into the analyzer chamber are not likely to be seen in CI because of the higher pressure inside the ionization chamber.
- 5 Half-split the system.
  - Close valves starting at the gas select valves (**Gas A** then **Gas B**), then close the shutoff valve. (See [Figure 4](#) on page 67 and [Table 7](#) on page 67.)
  - Cool and vent the MSD, remove the GC column, and cap off the interface.

Using argon or other introduced gas to find air leaks does not work well for the reagent gas flow system. It takes as long as 15 minutes for the peak to reach the ion source if the leak is at the inlet to the flow module.

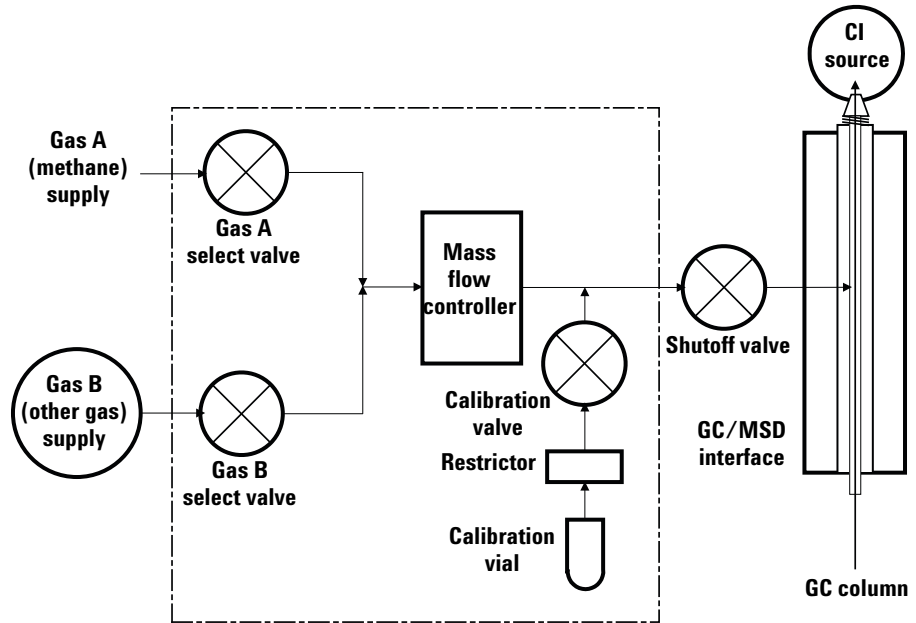

**Figure 4** Schematic of CI flow control module

**Table 7** Flow module valve state diagram

Result	Gas A flow	Gas B flow	Purge with Gas A	Purge with Gas B	Pump out flow module	Standby, vented, or EI mode
Gas A	Open	Closed	Open	Closed	Closed	Closed
Gas B	Closed	Open	Closed	Open	Closed	Closed
MFC	On (at setpoint)	On (at setpoint)	On (at 100%)	On (at 100%)	On (at 100%)	Off (at 0%)
Shutoff valve	Open	Open	Open	Open	Open	Closed

## Pressure-Related Symptoms

The following symptoms are all related to high vacuum pressure. Each symptom is discussed in more detail in the following pages.

The MFC is calibrated for methane, and the high vacuum gauge controller is calibrated for nitrogen, so these measurements are not accurate in absolute terms. (See [Table 8](#)). They are intended as a guide to typical observed readings. They were taken with the following set of conditions:

Source temperature	250 °C
Quad temperature	150 °C
Interface temperature	280 °C
Helium carrier gas flow	1 mL/min

**Table 8** Pressure measurements

Pressure (Torr)		
MFC (%)	Methane	Ammonia
10	$5.5 \times 10^{-5}$	$5.0 \times 10^{-5}$
15	$8.0 \times 10^{-5}$	$7.0 \times 10^{-5}$
20	$1.0 \times 10^{-4}$	$8.5 \times 10^{-5}$
25	$1.2 \times 10^{-4}$	$1.0 \times 10^{-4}$
30	$1.5 \times 10^{-4}$	$1.2 \times 10^{-4}$
35	$2.0 \times 10^{-4}$	$1.5 \times 10^{-4}$
40	$2.5 \times 10^{-4}$	$2.0 \times 10^{-4}$



## Poor vacuum without reagent gas flow

### Excess water in the background

Scan from 10 to 40  $m/z$ . A large peak at  $m/z$  19 ( $>m/z$  17) indicates water in the background. If water is present, allow the instrument to bake out more, and flow reagent gas through the lines to purge any accumulated water.

### Air leak

Run Methane Pretune. Refer to the *Operating Manual*. A visible peak at  $m/z$  32 indicates air in the system. Check for, and correct any leaks. (See “*Air Leaks*” on page 64.)

### The foreline pump is not working properly

For the standard foreline pump, replace the pump oil. If that does not help, or for the dry foreline pump, it may be necessary to replace the pump. Contact your local Agilent Technologies Customer Engineer.

### The turbo pump is not working properly

Check the pump speed. It should be at least 95%. Contact your local Agilent Technologies service representative.

#### CAUTION

Use of ammonia as reagent gas can shorten the life of the foreline pump oil (with standard pump) and possibly of the foreline pump itself.

---

## High pressure with reagent gas flow

### The reagent gas flow rate is too high

On the flow controller, turn down reagent gas flow as appropriate. Verify that reagent ion ratios are correct.

### Air leak

Run Methane Pretune. Refer to the *Operating Manual*. A visible peak at  $m/z$  32 indicates air in the system. Check for, and correct any leaks. (See “*Air Leaks*” on page 64.)

### Interface tip seal is not installed

Check the source storage box. If the seal is not in the box, vent the MSD and verify that the seal is correctly installed.

## **Pressure does not change when reagent flow is changed**

### **The reagent gas regulator is closed**

Check and, if necessary, open the reagent gas regulator.

### **The reagent gas regulator is set to the wrong pressure**

Set the reagent gas regulator to 10 psi (70 kPa) for methane or to 3 to 10 psi (20 to 70 kPa) for isobutane or ammonia.

### **The valve on the reagent gas bottle is closed**

Check and, if necessary, open the valve on the reagent gas bottle.

### **The reagent gas supply is empty**

Check and, if necessary, replace the reagent gas supply.

### **Reagent lines kinked, bent, pinched, or disconnected**

Inspect the reagent lines, and repair any defects. Check especially to ensure the reagent line is connected to the rear of the flow module. Ensure the methane line is connected to the Gas A inlet.

### **GC/MSD interface clogged or damaged**

Check for flow, and repair or replace components as indicated.

## Signal-Related Symptoms

This section describes symptoms related to the signal. The symptom may be too much signal, too little signal, a noisy signal, or an incorrect signal. Signal-related symptoms are generally observed during tuning, but may also be observed during data acquisition.

Error messages in autotune due to insufficient signal may vary.

The following symptoms are covered in more detail in this section:

- No peaks, see [page 73](#).
- No or low reagent gas signal, see [page 75](#).
- No or low PFDTD signal, see [page 77](#).
- Excessive noise, see [page 78](#).
- Low signal-to-noise ratio, see [page 78](#).
- Large peak at  $m/z$  19, see [page 79](#).
- Peak at  $m/z$  32, see [page 80](#).

## No peaks

When troubleshooting no peaks, it is important to specify what mode of operation is being used, and what expected peaks are not being seen. Always start with methane PCI and verify presence of reagent ions.

## No reagent gas peaks in PCI

### If the MSD has been working well and nothing seems to have been changed

- Wrong tune file loaded, or tune file corrupted
- Wrong ion polarity (there are no reagent ions visible in NCI)
- No reagent gas flow; look for background ions, and check pressure
- Wrong reagent gas selected for the tune file (looking for wrong ions)
- Large air leak
- Dirty ion source
- Poor vacuum (pump problem). (See [“Poor vacuum without reagent gas flow”](#) on page 69.)

### If the MSD was recently switched from EI to CI

- Isolation tip not installed
- No reagent gas flow
- Analyzer not sealed (big air leak)
- Wrong tune file loaded or tune file corrupted
- Ion source not assembled or connected correctly
- Wrong reagent gas selected for the tune file (looking for wrong ions)

## No PFDTD peaks in PCI

- Incorrect reagent gas. There are **no** PCI PFDTD peaks created with isobutane or ammonia. Switch to methane.
- Analyzer not sealed (big air leak)
- No calibrant in vial
- Defective calibration valve(s)
- Air leak in carrier or reagent gas path

#### **No reagent gas peaks in NCI**

- Reagent gases do not ionize in NCI; look for background ions instead.
- Verify tune parameters.
- If no background ions are visible, go back to methane PCI.

#### **No PFDTD calibrant peaks in NCI**

- Look for background ions: 17 (OH<sup>-</sup>), 35 (Cl<sup>-</sup>), and 235 (ReO3<sup>-</sup>).
- Verify tune parameters.
- Go back to methane PCI.

#### **No sample peaks in NCI**

- Look for background ions: 17 (OH<sup>-</sup>), 35 (Cl<sup>-</sup>), and 235 (ReO3<sup>-</sup>).
- Go back to methane PCI.
- Poor quality reagent gas (purity less than 99.99%).

#### **Large peak at $m/z$ 238 in NCI OFN spectrum**

- Look for background ions: 17 (OH<sup>-</sup>), 35 (Cl<sup>-</sup>), and 235 (ReO3<sup>-</sup>).
- Find and fix your small air leak.

## No or low reagent gas signal

**If you have just installed the CI source and have an air leak or large amounts of water in the system after running one or more autotunes, the ion source is probably dirty.**

Fix the air leak. Clean the ion source, and bake out for 2 hours before tuning. Refer to the *Operating Manual*.

**The wrong reagent gas is flowing.**

Turn on the correct reagent gas for your tune file.

**Ion polarity is set to Negative. No reagent gas ions are formed in NCI.**

Switch to Positive ionization mode.

**The reagent gas flow is set too low.**

Increase the reagent gas flow.

**Reagent gas supply tubing is blocked, kinked, pinched, or disconnected.**

Inspect and, if necessary, repair or replace the reagent gas supply tubing.

**Wrong filament wires are connected to filament.**

Ensure that the filament 1 wires are connected to the CI source filament, and that the filament 2 wires are connected to the dummy filament.

**Carbon has built up on the filament, or the filament has sagged out of alignment.**

Inspect the filament, if necessary, replace the filament.

**Too much air or water in the system.**

Run the methane pretune. Peaks at  $m/z$  32 and 19 usually indicate air and water, respectively. Bake out and purge the instrument until there is no visible peak at  $m/z$  32, and the peak at  $m/z$  19 is reduced to a very low level. If the peak at  $m/z$  32 does not decrease, an air leak is likely. (See “Air Leaks” on page 64.)

**The signal cable is not connected.**

Check and, if necessary, reconnect the signal cable.

**The filament or filament support is shorted to the ion source body or repeller.**

Inspect the filament, if necessary, realign the filament support arms.

**The electron inlet hole is blocked.**

Inspect the electron inlet hole and, if necessary, clean the hole with a clean toothpick and a slurry of aluminum oxide powder and methanol. If the electron inlet hole is that dirty, the entire ion source probably needs to be cleaned.

**Ion source wires are not connected, or incorrectly connected.**

Inspect the repeller. Ensure the repeller lead is firmly attached to the repeller. Inspect the wires to the ion focus and entrance lenses. If the connections are reversed, correct the problem.

**One of the detector leads (in the analyzer chamber) is not connected.**

Check and, if necessary, reconnect the EMleads.

**Saturated methane/isobutane gas purifier**

Replace the gas purifier.

**Poor quality methane (purity below 99.99%)**

Replace the methane with high-purity methane. If necessary, clean and purge the reagent gas lines and clean the ion source.



## No or low PFDTD signal, but reagent ions are normal

### You are using any reagent gas but methane in PCI.

Switch to methane.

### Wrong or corrupted tune file loaded

Check your tune file.

### No PFDTD in the calibrant vial

Inspect the calibration vial on the back of the flow controller. If necessary, fill the vial with PFDTD. Do not fill the vial completely; keep the level at least 0.5 cm from the top of the vial.

### The pressure of the methane entering the flow controller is too high.

Ensure the regulator on the methane supply is set to 10 psig (70 kPa).

### The CI source is dirty.

Clean the ion source.

### The calibration valve was not purged after the vial was refilled.

Purge the calibration valve. (See [“To Purge the Calibration Valves”](#) on page 120.) Then clean the ion source.

### The calibrant vial was overfilled. Excess PFDTD can quench the chemical ionization reactions.

Check the level of the PFDTD in the calibration vial. It should be *below* the end of the inside tube in the vial.

### Poor quality methane (purity below 99.99%)

Replace the methane with high-purity methane. If necessary, clean and purge the reagent gas lines and clean the ion source.

## Excessive noise or low signal-to-noise ratio

### **The GC inlet needs maintenance.**

Refer to the GC manual.

### **The CI source is dirty.**

Clean the ion source.

### **Poor vacuum**

Check the pressure on the high vacuum gauge controller.

### **Air leak**

Run Methane Pretune (in PCI). A large peak at  $m/z$  32 indicates air in the system. Check for, and correct any leaks. See “[Air Leaks](#)” on page 64.)

### **Saturated methane/isobutane gas purifier**

Replace the gas purifier.

### **Poor quality methane (purity below 99.99%)**

Replace the methane with high-purity methane. If necessary, clean and purge the reagent gas lines and clean the ion source.

### **Reagent gas flows too high (in EI/PCI MSDs)**

Verify that the reagent gas setup is correct.

## Large peak at $m/z$ 19

If the abundance of the peak at  $m/z$  19 is more than half abundance of the peak at  $m/z$  17, there probably is too much water in the system.

### **The system was not baked out sufficiently after it was last vented.**

Bake out the system. (See [Chapter 4](#), “General Maintenance,” starting on page 87.)

### **Moisture left over in the reagent gas supply tubing and flow module**

Purge the reagent gas supply lines for at least 60 minutes.

### **Contaminated reagent gas supply**

Replace the reagent gas supply, and purge the lines and flow module.

### **Saturated methane/isobutane gas purifier**

Replace the gas purifier.

#### Peak at $m/z$ 32

A visible peak at  $m/z$  32 in methane pretune often indicates air in the system.

**Residual air from recent venting — check for water indicated by a large peak at  $m/z$  19.**

To eliminate water, bake out the system under vacuum.

#### **New or dirty reagent gas supply tubing**

Purge the reagent gas supply lines and flow module *for at least 60 minutes*. Refer to the *Operating Manual*.

#### **Air leak**

Check for leaks, and correct any that you find. (See “Air Leaks” on page 64.) After all leaks have been corrected, clean the ion source.

**Contaminated reagent gas supply. Suspect this if you have recently replaced your gas tank, and you have ruled out air leaks.**

Replace the reagent gas supply.

#### **The capillary column is broken or disconnected.**

Inspect the capillary column. Ensure it is not broken and it is installed correctly.

#### **Saturated methane/isobutane gas purifier**

Replace the gas purifier.

## Tuning-Related Symptoms

This section describes symptoms related to tuning. Most symptoms involve difficulties with tuning or with the results of tuning. The following symptoms are covered in this section:

- CI ratio is difficult to adjust or unstable
- High EMV
- Cannot complete autotune
- Peak widths are unstable

## Reagent gas ion ratio is difficult to adjust or unstable

### **The interface tip seal is incorrectly placed, damaged, or missing.**

Inspect the isolation tip. If necessary, remove and reinstall it to ensure a good seal with the CI source. Replace it if it is damaged. Install it if it is missing.

### **Residual air and water in the MSD or in the reagent gas supply lines**

Run the methane pretune. Air will appear as a peak at  $m/z$  32 and excessive water as a peak at  $m/z$  19 >  $m/z$  17. If either of these conditions is present, purge the reagent gas supply lines and bake out the MSD. (See [“To Clean the Reagent Gas Supply Lines”](#) on page 139.) Continued presence of a large peak at  $m/z$  32 may indicate an air leak. After correcting the problems, you may need to clean the ion source.

### **Air leak**

Run Methane Pretune (in PCI). Large peak at  $m/z$  32 indicates air in the system. Check for and correct any leaks. (See [“Air Leaks”](#) on page 64.)

### **The reagent gas supply is at the wrong pressure.**

Check the regulator on the reagent gas supply. It should be adjusted to 20 psi (140 kPa).

### **A leak in the reagent gas delivery path.**

This is especially likely if you have set the methane flow much higher than normal and the ratio is still too low.

Check the reagent gas path. Tighten fittings.

### **The CI source is dirty.**

Clean the ion source.

## High EMV

The EMV can range from a few hundred volts to 3,000 V. If the CI autotune program consistently sets the EMV at or above 2,600 V but can still find peaks and complete the tune, it may indicate a problem.

### **The filament is worn out.**

The CI filament may wear out without actually breaking. Check the Electron Energy ramp; the curve should have a definite maximum with an inflection point. If the curve is linear with a positive slope and no inflection point, and the EMV is high, the filament has stretched to the point where it does not line up with the hole in the ion source body, and most electrons are not getting into the source.

Replace the filament.

### **The analyzer is not at the proper operating temperature.**

Verify the ion source and quadrupole temperatures. The default source temperature is 250 °C for PCI and 150 °C for NCI. The quadrupole temperature is 150 °C for both CI modes.

### **The CI source is dirty.**

Clean the ion source.

### **The EM(detector) is failing. Switch to EI mode and confirm.**

Replace the electron multiplier.

## Cannot complete Autotune

### **Wrong or corrupted tune file**

Check the tune parameters.

**The  $m/z$  28/27 ion ratio (for methane) is incorrect. The correct ratio should be between 1.5 and 5.0.**

If the ion ratio is incorrect, adjust it. Refer to the *Operating Manual*.

### **The CI source is dirty.**

Clean the source.

### **Too much air or water in the system**

After eliminating these problems, clean the ion source. (See “[Air Leaks](#)” on page 64.)



## Peak widths are unstable

### **Wrong or corrupted tune file**

Check the tune parameters.

### **The CI source is dirty.**

Clean the ion source.

### **Air leak**

Run Methane Pretune (in PCI). A visible peak at  $m/z$  32 indicates air in the system. Check for and correct any leaks. (See “[Air Leaks](#)” on page 64.) After eliminating all air leaks, clean the ion source.

### **3 CI Troubleshooting**

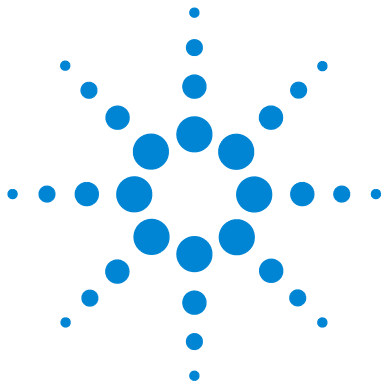

## 4 General Maintenance

Before Starting	88
Maintaining the Vacuum System	93
To Separate the MSD from the GC	94
To Move or Store the MSD	96
To Reconnect the MSD to the GC	98
To Check the Foreline Pump Fluid	99
To Drain the Foreline Pump	101
To Refill the Foreline Pump	102
To Change the Blue Oil Mist Filter on the Foreline Pump	103
To Install the Exhaust Filter on the IDP3 Dry Pump	104
To Change the Filter Cartridge on the IDP3 Dry Foreline Pump	105
To Check the DP Fluid	106
To Remove the DP	108
To Replace the DP Fluid	110
To Install the DP	113
To Remove the Foreline Gauge	115
To Install the Foreline Gauge	117
To Refill the EI Calibration Vial	118
To Purge the Calibration Valves	120
To Remove the EI Calibration and Vent Valve Assembly	121
To Install the EI Calibration and Vent Valve Assembly	122
To Replace the Fan for the High Vacuum Pump	123
To Remove the Ion Vacuum Gauge	125
To Install an Ion Vacuum Gauge	126
To Lubricate the Side Plate O-Ring	127
To Lubricate the Vent Valve O-Ring	129
Maintaining the Electronics	131
To Adjust the Quad Frequency	133
To Replace the Primary Fuses	135



### Before Starting

For your safety, read all of the information in this introduction before performing any maintenance tasks.

### Scheduled maintenance

Performing common maintenance tasks when scheduled can reduce operating problems, prolong system life, and reduce overall operating costs. (See [Table 9.](#))

Keep a record of system performance (tune reports) and maintenance operations performed. This makes it easier to identify variations from normal operation, and to take corrective action.

**Table 9** Maintenance schedule

Task	Every week	Every 6 months	Every year	As needed
Tune the MSD				X
Check the foreline pump oil level	X			
Check the calibration vial(s)		X		
Replace the foreline pump oil <sup>†</sup>		X		
Replace the DP fluid			X	
Check the dry foreline pump				X
Change the dry foreline pump tip seal			X	
Change the foreline pump exhaust filter				X
Clean the ion source				X
Check the carrier gas trap(s) on the GC and MSD				X
Replace the worn out parts				X
Lubricate sideplate or vent valve O-rings <sup>*</sup>				X
Replace CI Reagent gas supply				X
Replace GC gas supplies				X

<sup>†</sup> Every 3 months for CI MSDs using ammonia reagent gas.

<sup>\*</sup> Vacuum seals other than the side plate O-ring and vent valve O-ring do not need to be lubricated. Lubricating other seals can interfere with their correct function.

## Tools, spare parts, and supplies

Some of the required tools, spare parts, and supplies are included in the GC shipping kit, MSD shipping kit, or MSD tool kit. You must supply others yourself. Each maintenance procedure includes a list of the materials required for that procedure. (See “Consumables and Maintenance Supplies” on page 240.)

## High voltage precautions

Whenever the MSD is plugged in, even if the power switch is off, potentially dangerous voltage (120 VAC or 200/240 VAC) exists on:

- The wiring and fuses between where the power cord enters the instrument and the power switch

When the power switch is on, potentially dangerous voltages exist on:

- Electronic circuit boards
- Toroidal transformer
- Wires and cables between these boards
- Wires and cables between these boards and the connectors on the back panel of the MSD
- Some connectors on the back panel (for example, the foreline power receptacle)

Normally, all of these parts are shielded by safety covers. As long as the safety covers are in place, it should be difficult to accidentally make contact with dangerous voltages.

### **WARNING**

**Do not perform maintenance with the MSD turned on or plugged into its power source unless you are instructed by one of the procedures in this chapter to do so.**

---

Some procedures in this chapter require access to the inside of the MSD while the power switch is on. Do not remove any of the electronics safety covers in any of these procedures. To reduce the risk of electric shock, follow the procedures carefully.

### Dangerous temperatures

Many parts in the MSD operate at, or reach, temperatures high enough to cause serious burns. These parts include, but are not limited to the:

- GC inlets
- GC oven and its contents, including the column nuts attaching the column to a GC inlet, GC/MS interface, or GC detector
- GC detector
- GC valve box
- Foreline pump
- Heated MSD ion source, interface, and quadrupole

#### **WARNING**

**Never touch these parts while your MSD is on. After the MSD is turned off, give these parts enough time to cool before handling them.**

---

#### **WARNING**

**The GC/MSD interface heater is powered by a heated zone on the GC. The interface heater can be on, and at a dangerously high temperature, even though the MSD is off. The GC/MSD interface is well insulated. Even after it is turned off, it cools very slowly.**

---

#### **WARNING**

**The foreline pump can cause burns if touched when operating. It has a safety shield to prevent the user from touching it.**

---

The GC inlets and GC oven also operate at very high temperatures. Use the same caution around these parts. See the documentation supplied with your GC for more information.

### Chemical residue

Only a small portion of your sample is ionized by the ion source. The majority of any sample passes through the ion source without being ionized. It is pumped away by the vacuum system. As a result, the exhaust from the foreline pump will contain traces of the carrier gas and your samples. Exhaust from the standard foreline pump also contains tiny droplets of foreline pump oil.

An oil trap is supplied with the standard foreline pump. This trap stops *only* pump oil droplets. It *does not* trap any other chemicals. If you are using toxic solvents or analyzing toxic chemicals, do not use this oil trap. For all foreline pumps, install a hose to take the exhaust from the foreline pump outdoors or into a fume hood vented to the outdoors. For the standard foreline pump, this requires removing the oil trap. Comply with your local air quality regulations.

**WARNING**

**The oil trap supplied with the standard foreline pump stops only foreline pump oil. It does not trap or filter out toxic chemicals. If you are using toxic solvents or analyzing toxic chemicals, remove the oil trap. Do not use the trap if you have a CI MSD. Install a hose to take the foreline pump exhaust outside or to a fume hood.**

---

The fluids in the DP and standard foreline pump also collect traces of the samples being analyzed. All used pump fluid should be considered hazardous and handled accordingly. Dispose of used fluid correctly, as specified by your local regulations.

**WARNING**

**When replacing pump fluid, use appropriate chemical-resistant gloves and safety glasses. Avoid all contact with the fluid.**

---

## Electrostatic discharge

All of the printed circuit boards in the MSD contain components that can be damaged by electrostatic discharge (ESD). Do not handle or touch these boards unless absolutely necessary. In addition, wires, contacts, and cables can conduct ESD to the electronics boards to which they are connected. This is especially true of the mass filter (quadrupole) contact wires which can carry ESD to sensitive components on the side board. ESD damage may not cause immediate failure, but it will gradually degrade the performance and stability of your MSD.

When you work on or near printed circuit boards, or when you work on components with wires, contacts, or cables connected to printed circuit boards, always use a grounded antistatic wrist strap and take other antistatic precautions. The wrist strap should be connected to a known good earth

## 4 General Maintenance

ground. If that is not possible, it should be connected to a conductive (metal) part of the assembly being worked on, but **not** to electronic components, exposed wires or traces, or pins on connectors.

Take extra precautions, such as a grounded antistatic mat, if you must work on components or assemblies that have been removed from the MSD. This includes the analyzer.

### CAUTION

To be effective, an antistatic wrist strap must fit snugly (not tight). A loose strap provides little or no protection.

Antistatic precautions are not 100% effective. Handle electronic circuit boards as little as possible and then only by the edges. Never touch components, exposed traces, or pins on connectors and cables.

---



## Maintaining the Vacuum System

### Periodic maintenance

Some maintenance tasks for the vacuum system must be performed periodically. (See [Table 9](#) on page 88.) These include:

- Checking the foreline pump fluid (every week)
- Checking the calibration vial (every 6 months)
- Replacing the foreline pump oil (every 6 months; every 3 months for CI MSDs using ammonia reagent gas, standard foreline pump)
- Tightening the foreline pump oil box screws (first oil change after installation, standard foreline pump)
- Changing the foreline pump exhaust filters
- Replacing the DP fluid (once a year)
- Changing the dry foreline pump tip seal (once a year)

Failure to perform these tasks as scheduled can result in decreased instrument performance. It can also result in damage to your instrument.

### Other procedures

Tasks such as replacing a Micro-Ion vacuum gauge should be performed only when needed. (See [“General Troubleshooting”](#) on page 33.) Refer to the online help in the Agilent MassHunter GC/MS Acquisition software for symptoms that indicate this type of maintenance is required.

### More information is available

If you need more information about the locations or functions of vacuum system components. (See [“Vacuum System”](#) on page 143.)

Most of the procedures in this chapter are illustrated with video clips on the 5977B Series MSD User Information media.

## To Separate the MSD from the GC

### Materials needed

- Wrench, open-end, 1/4-inch × 5/16-inch (8710-0510)

### Procedure

- 1 Vent the MSD.
- 2 Turn off the GC.

### WARNING

Ensure the GC/MSD interface and GC oven have cooled before you remove the column.

- 3 Remove the capillary column from the GC/MSD interface.
- 4 The foreline pump may be located on the floor, on the lab bench next to or behind the MSD, or under the analyzer chamber at the back of the MSD. Move it as needed to provide slack in the tubing and cables.
- 5 Move the MSD away from the GC until you have access to the GC/MSD interface cable. (See [Figure 5](#).)

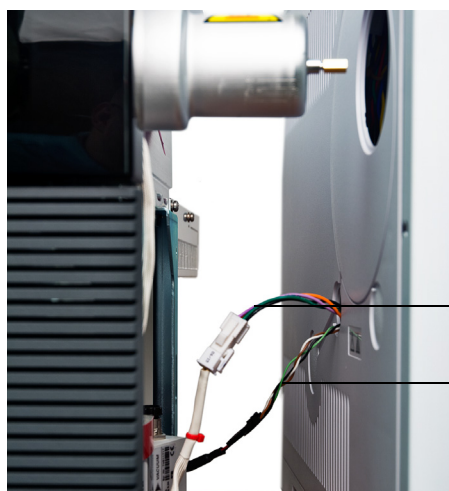

The Agilent 7890 GC has a front and a back location for the MSD interface.

The Agilent 7820A GC has only one location for the MSD interface.

Interface cable

LVDS cable

**Figure 5** Separating and connecting the MSD and GC

- 6** Place a column nut with a blank ferrule on the end of the interface. This will help keep contamination out of the MSD.
- 7** Disconnect the GC/MSD interface cable and the LVDS cable (if applicable). Disconnecting either cable with the GC on can cause a fault condition.
- 8** Continue to move the MSD until you have access to the part requiring maintenance.

### To Move or Store the MSD

#### Materials needed

- Ferrule, blank (5181-3308)
- Interface column nut (05988-20066)
- Wrench, open-end, 1/4-inch × 5/16-inch (8710-0510)

#### Procedure

- 1 Vent the MSD.
- 2 Remove the column, and install a blank ferrule and interface nut.
- 3 Tighten the vent valve.
- 4 Move the MSD away from the GC.
- 5 Disconnect the GC/MSD interface heater cable and the LVDS cable from the GC (if applicable).
- 6 Install the interface nut with the blank ferrule.
- 7 Open the analyzer cover.
- 8 Finger-tighten the side plate thumbscrews. (See [Figure 6](#) on page 97.)

#### CAUTION

Do not overtighten the side plate thumbscrews. Overtightening will strip the threads in the analyzer chamber. It will also warp the side plate and cause leaks.

- 9 Plug the MSD power cord in.
- 10 Switch the MSD on for 5 minutes to establish a rough vacuum.
- 11 Switch the MSD off.
- 12 Close the analyzer cover.
- 13 Disconnect the LAN, remote, and power cables.

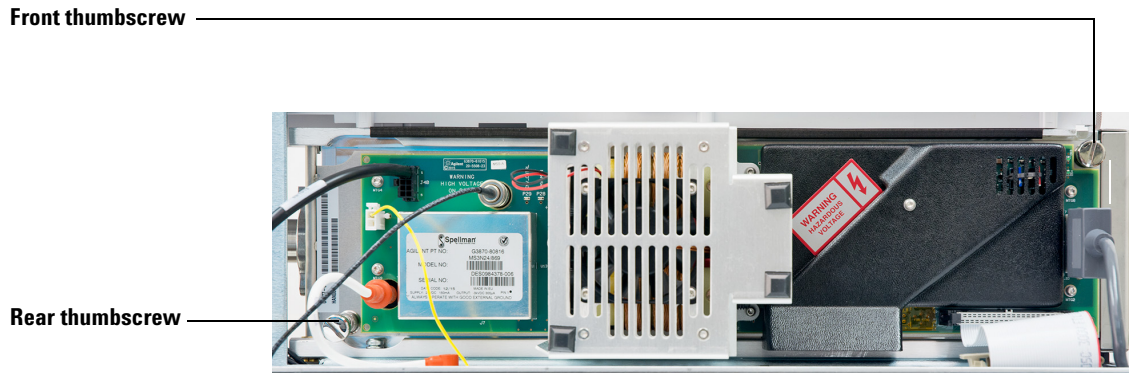

**Figure 6** Side plate thumbscrews

The MSD can now be stored or moved. The foreline pump cannot be disconnected; it must be moved with the MSD. Ensure the MSD remains upright, and is never tipped on its side or inverted.

**CAUTION**

The MSD must remain upright at all times. If you need to ship your MSD to another location, contact your Agilent Technologies service representative for advice about packing and shipping.

## To Reconnect the MSD to the GC



### Materials needed

- Wrench, open-end, 1/4-inch × 5/16-inch (8710-0510)

### Procedure

- 1 Position the MSD so the end of the GC/MSD interface is near the GC.
- 2 Reconnect the GC/MSD interface and the LVDS cables (if applicable).
- 3 Slide the MSD to its regular position next to the GC.

Be careful not to damage the GC/MSD interface as it passes into the GC. Ensure the end of the GC/MSD interface extends into the GC oven.

- 4 The foreline pump may be located on the floor, on the lab bench next to or behind the MSD, or under the analyzer chamber at the back of the MSD.
- 5 Reinstall the capillary column.
- 6 Pump down the MSD.
- 7 Turn on the MS and GC. Enter appropriate temperature setpoints for the GC/MSD interface and GC oven.

## To Check the Foreline Pump Fluid

Wet foreline pumps only



### Materials needed

- Foreline pump oil (6040-0621)
- Funnel (9301-6461)
- Hex key to remove drain plug (5 mm for Pfeiffer pump, 8710-1838)
- Screwdriver, flat-blade, to remove top fill cap

### Procedure

Always replace the oil if it is dark or cloudy or due for replacement instead of adding oil. (See [“To Drain the Foreline Pump”](#) on page 101 and [“To Refill the Foreline Pump”](#) on page 102.)

### WARNING

**The foreline pump can cause burns if touched when operating. It has a safety shield to prevent the user from touching it.**

---

- 1 Examine the oil level window ([Figure 7](#) on page 100).
- 2 Note the two lines on the pump left of the window. The oil level should be between the lines. The foreline pump oil should be almost clear. If the oil level is near or below the lower line, add foreline pump oil. (See [“To Refill the Foreline Pump”](#) on page 102, starting at step four.)

### WARNING

**Never add oil while the foreline pump is on.**

---

## 4 General Maintenance

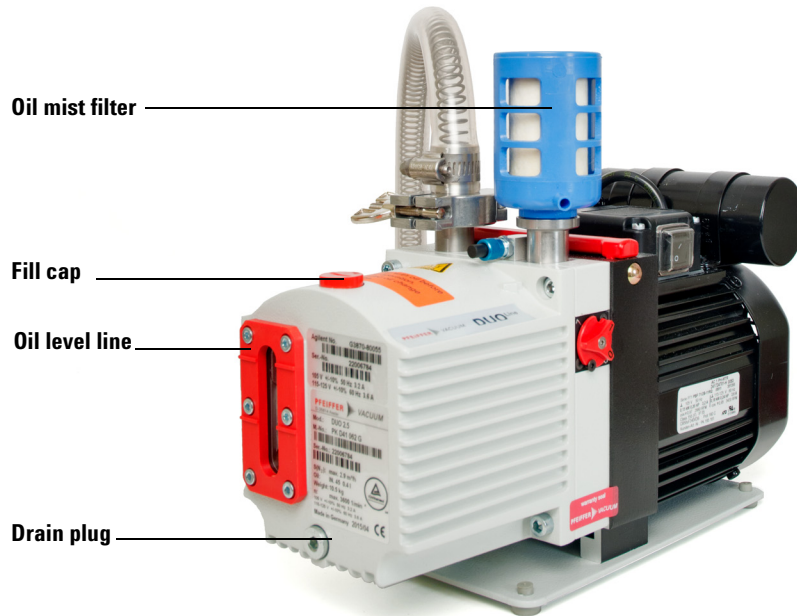

**Figure 7** Pfeiffer Duo 2.5 foreline pump



## To Drain the Foreline Pump

Wet foreline pump only



### Materials needed

- Book or other solid object approximately 5 cm thick
- Container for catching old pump oil, 500 mL
- Gloves, oil- and solvent-resistant
- Screwdriver, flat-blade, large (8730-0002)
- Hex key to remove drain plug (5 mm for Pfeiffer pump, 8710-1838)

### Procedure

#### WARNING

**The foreline pump can cause burns if touched when operating. It has a safety shield to prevent the user from touching it.**

---

- 1 Vent the MSD.
- 2 If necessary, slide the foreline pump to a safe, accessible location.

The foreline pump may be located on the floor, on the lab bench next to or behind the MSD, or under the analyzer chamber at the back of the MSD.

- 3 Remove the fill cap. (See [Figure 7](#) on page 100.)
- 4 Place a container under the drain plug.
- 5 Remove the drain plug. Allow the pump oil to drain out. The oil drains faster if it is still warm.

If necessary, you can place a book or other object under the pump motor to tilt it up slightly.

#### WARNING

**The old pump oil may contain toxic chemicals. Treat it as hazardous waste.**

---

- 6 Replace the drain plug after draining the oil.

## To Refill the Foreline Pump

Standard foreline pump only



### Materials needed

- Foreline pump oil (6040-0621) – approximately 0.28 L required
- Funnel (9301-6461)
- Gloves, oil- and solvent-resistant
- Screwdriver, flat-blade, large (8730-0002)
- Drain plug O-ring (if required) (0905-1515)
- Hex key to remove drain plug (5 mm for Pfeiffer pump, 8710-1838)

### Procedure

#### **WARNING**

**The foreline pump can cause burns if touched when operating. It has a safety shield to prevent the user from touching it.**

---

- 1 Drain the foreline pump. (See [“To Drain the Foreline Pump”](#) on page 101.)
- 2 Reinstall the drain plug. If the old O-ring appears worn or damaged, replace it.
- 3 Remove the propping object from under the pump motor.
- 4 Add foreline pump oil until the oil level in the window is near, but not above, the upper line. The foreline pump requires approximately 0.28 L of oil.
- 5 Wait a few minutes for the oil to settle. If the oil level drops, add oil to bring the oil level near the upper line.
- 6 Reinstall the fill cap.
- 7 If necessary, slide the foreline pump back under the analyzer chamber.

The foreline pump may be located on the floor, on the lab bench next to or behind the MSD, or under the analyzer chamber at the back of the MSD.

- 8 Pump down the MSD.

## To Change the Blue Oil Mist Filter on the Foreline Pump



### Materials needed

- Blue mist filter (G1099-80039)

### Procedure

- 1 Disconnect the foreline pump exhaust hose from the filter.
- 2 Unscrew the filter from the top of pump.
- 3 Screw the replacement filter on to the pump and replace the exhaust hose.

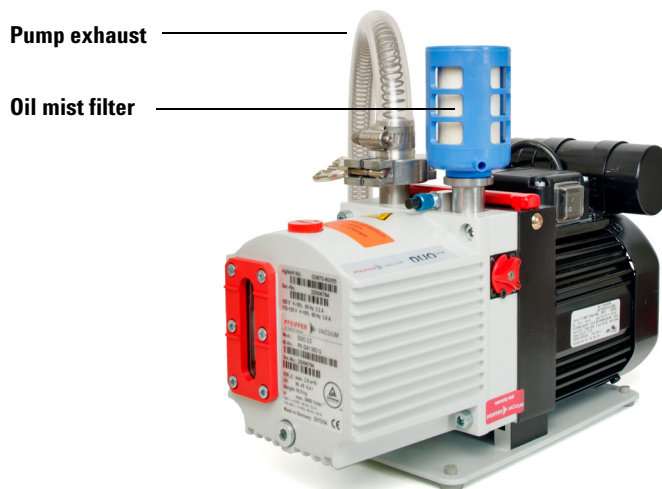

**Figure 8** Foreline Pump with oil mist filter

## To Install the Exhaust Filter on the IDP3 Dry Pump



### Materials needed

- Exhaust filter (G3170-80041)

### Procedure

- 1 Disconnect the foreline pump exhaust hose from the adapter.
- 2 Unscrew the adapter from the pump.
- 3 Screw the filter on to the pump.

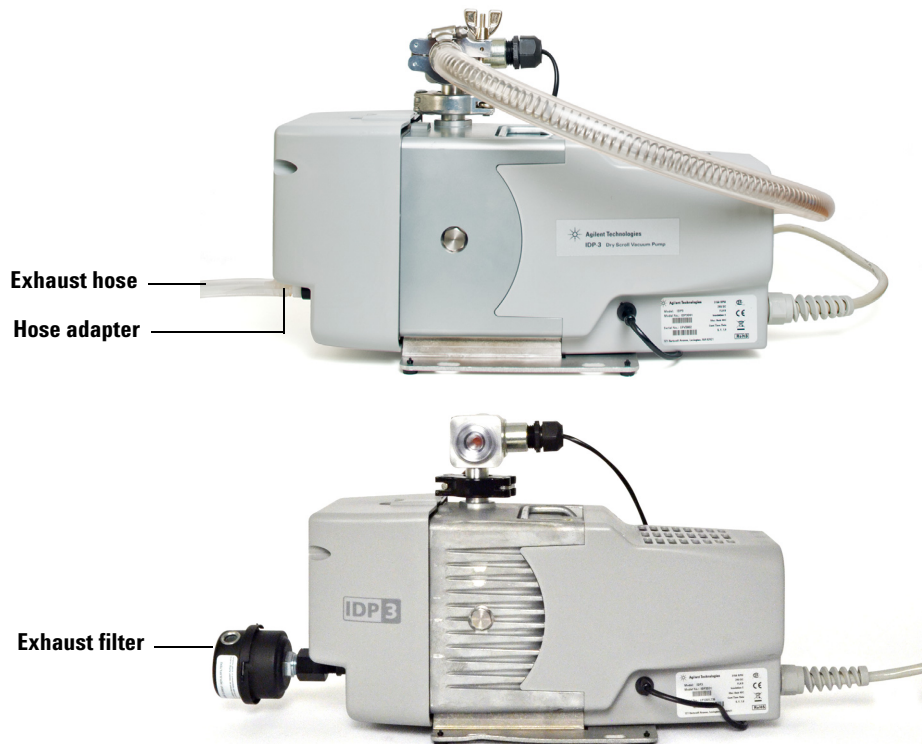

**Figure 9** IDP3 pump with exhaust filter

## To Change the Filter Cartridge on the IDP3 Dry Foreline Pump



### Materials needed

- Exhaust filter cartridge (G3170-80041)

### Procedure

- 1 Unscrew the cap from the exhaust filter. (See [Figure 9](#) on page 104.)
- 2 Pull the filter cartridge out of the filter cap.
- 3 Replace the filter cartridge.
- 4 Align the cap onto the filter and the cap counter clockwise to lock in place.

## To Check the DP Fluid



### Materials needed

- Screwdriver, Torx T-20 (8710-1615)

### Procedure

- 1 Remove the analyzer window cover.

---

### WARNING

**Do not remove any other covers. Removing other covers may expose hazardous voltages.**

- 2 Vent the MSD.
- 3 Remove the side cover.

---

### WARNING

**Keep your hair away from the cooling fan if the MSD is turned on.**

- 4 Check the DP fluid level. (See [Figure 10](#) on page 107.)

The DP fluid level can be seen through the window below the fan at the front of the MSD. The DP fluid level should be between the top and bottom of one of the **FULL** ranges. There are two sets of marks. Use the **HOT** marks if the DP is on and is at its normal operating temperature. Use the **COLD** marks if the pump is off and has had time to cool. If the fluid level is below the bottom of the appropriate range, replace the DP fluid. Do not just add fluid.

The pump fluid should be clear or almost clear. Dark or cloudy pump fluid indicates an air leak or excessive heat. If the pump fluid appears dark or cloudy, replace it. Then, check for an air leak.

The DP fluid should be replaced at least once a year, or more often if the pump fluid level is low, or if the fluid is dark or cloudy.

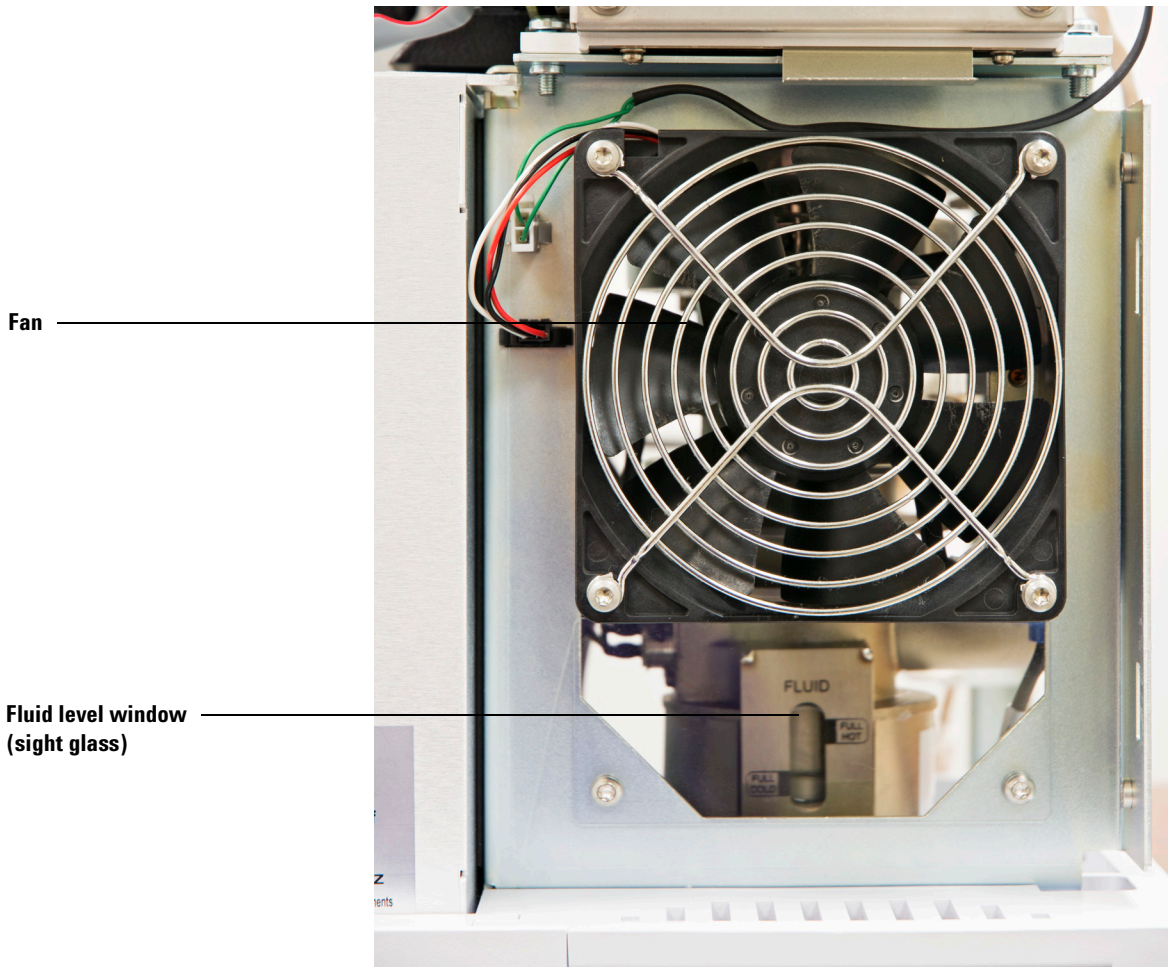

Figure 10 DP

## To Remove the DP

**WARNING**

Treat the DP fluid as hazardous, as it may contain traces of toxic chemicals.

---



### Materials needed

- Aluminum foil, clean
- Gloves, oil-resistant

### Procedure

- 1 Vent the MSD.
- 2 Separate the MSD from the GC. (See [“To Separate the MSD from the GC”](#) on page 94.)
- 3 Disconnect high vacuum power (HIVAC POWER) cable from the back panel of the MSD. (This is the thick black cable that emerges near the bottom of the pump.)
- 4 Disconnect the DP temperature sensor wires from the wiring harness.
- 5 Support the DP with one hand.



- 6 Remove the KF50 clamp. (See [Figure 11](#).)

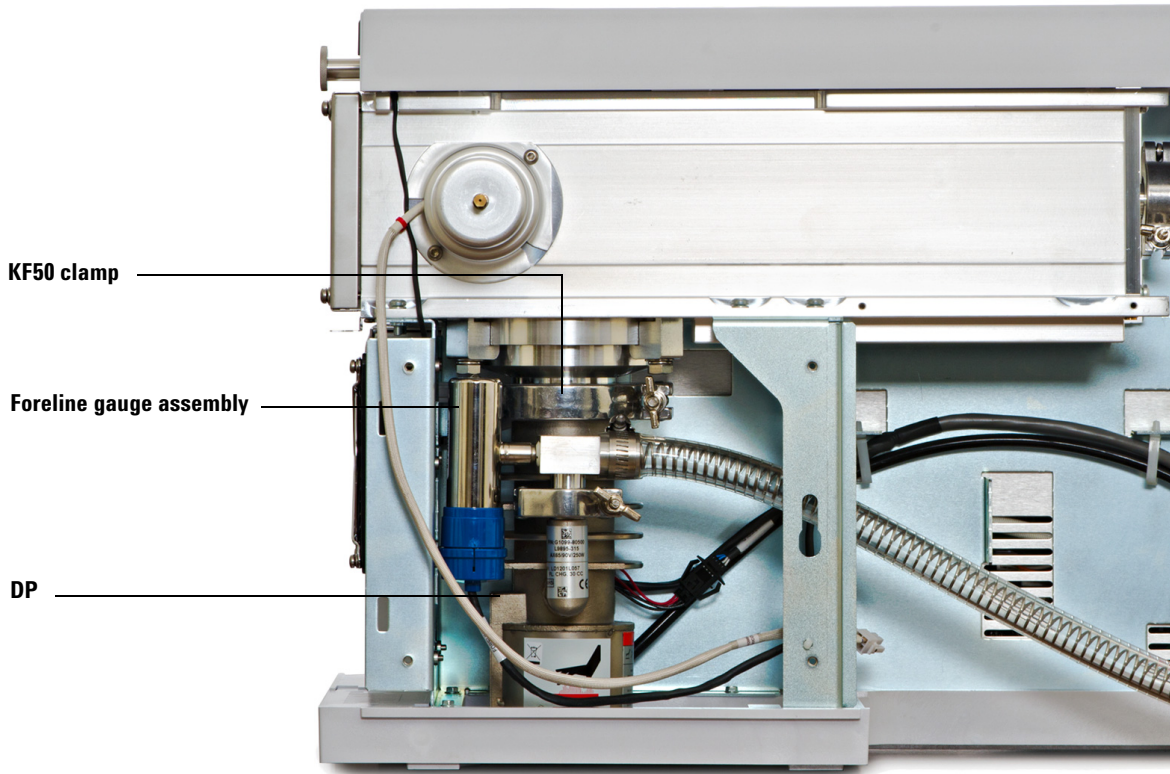

**Figure 11** Removing the DP

- 7 Lower the DP.
- 8 Remove the O-ring assembly from the top of the DP. The O-ring will have DP fluid on it, and will be very sticky. Place the O-ring on clean aluminum foil (shiny side down) to keep your lab bench and the O-ring clean.
- 9 Remove the DP through the side of the MSD. You may have to tilt the pump slightly to remove it. Do not tilt the pump past 45 degrees if the pump is warm.
- 10 Disconnect the foreline gauge assembly from the DP outlet. The foreline gauge cable can be disconnected or can remain connected to the foreline gauge.

## To Replace the DP Fluid



### Materials needed

- Aluminum foil, clean
- Cloths, clean, lint-free (05980-60051)
- Container for old DP fluid
- DP fluid, 18.5 mL (6040-0809) – Two bottles are required
- Gloves
  - Oil- and solvent-resistant
  - Thermally insulated

### Procedure

- 1 Remove the DP from the MSD. (See “[To Remove the DP](#)” on page 108.) Remove the O-ring assembly from the top of the DP.
- 2 Cover the top of the DP with aluminum foil (shiny side up).

---

**WARNING**

**The pump and pump fluid will be hot. Wear protective gloves when you remove the pump from the oven.**

- 3 Heat the DP at 60 °C for 15 minutes. (For 7820A or 7890 GC's you can use the GC oven.)

---

**WARNING**

**Treat the old pump fluid as hazardous. It may contain traces of toxic chemicals.**

- 4 Pour the old DP fluid out the top of the pump. Even after heating, the pump fluid pours very slowly.

---

**WARNING**

**Methylene chloride is a hazardous solvent. Work in a fume hood and take all appropriate precautions.**

- 5 Check the color of the pump fluid.

If the DP has been heated with insufficient pump fluid (or with a large air leak in the MSD), the remaining pump fluid may be severely charred and blackened. Blackened pump fluid may also be baked onto the internal parts (stack) of the pump. If so, you may have to remove the DP stack and clean its parts, and the interior of the pump, with methylene chloride. Be very careful when reinstalling the stack. Misalignment of stack components can seriously reduce DP performance.

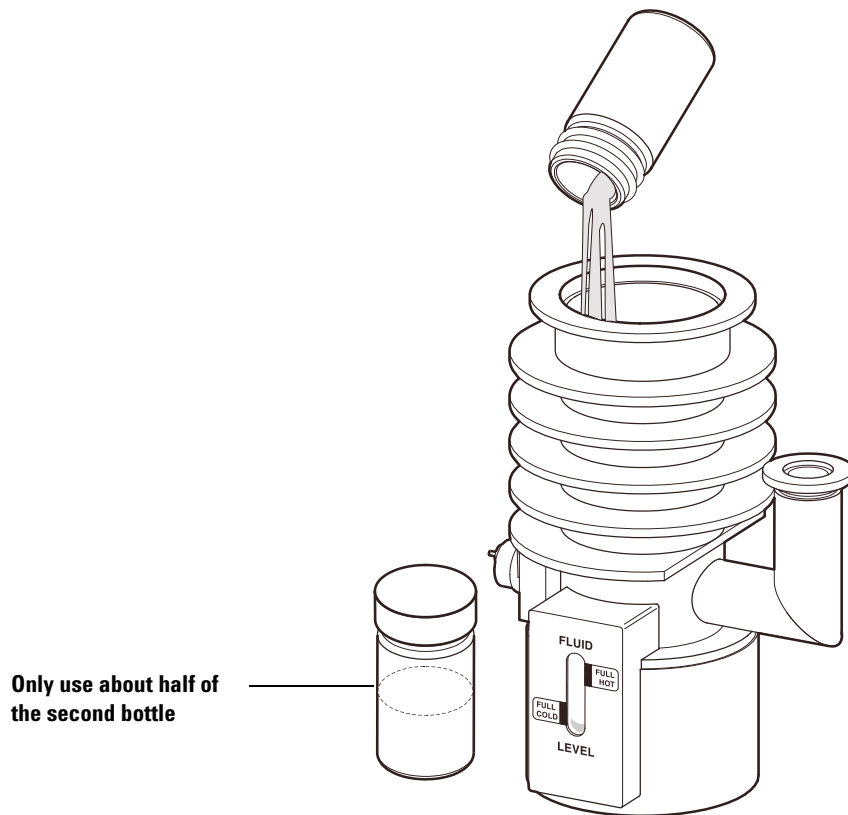

**Figure 12** Filling the DP with fluid

- 6 Clean the DP flange on the analyzer chamber.
- 7 Preheat the new DP fluid following the instructions on the bottle.

## 4 General Maintenance

- 8 Pour new DP fluid into the DP until the fluid level is within the FULL COLD range.

The recommended charge for this pump is 30 mL. It will require approximately 1.5 of the bottles (18.5 mL each) of DP fluid. Pour the fluid between the center stack and the side wall. Watch the sight glass while pouring. Do not overfill.

- 9 Reinstall the DP. (See [“To Install the DP”](#) on page 113.)

## To Install the DP



### Materials needed

- Gloves, oil-resistant
- Vacuum cleaner, non-ESD generating (92175V or equivalent)

This procedure works best with two people, one to hold the pump, and one to install the clamp.

### Procedure

- 1** Vacuum the fan that cools the DP.  
Keeping the fan clean helps ensure maximum cooling. This is one of the few times you will have convenient access to the pump side of the fan.
- 2** Slide the DP into the MSD.  
You may have to tilt the pump slightly to get it into the MSD. Do not tilt it past 45 degrees.
- 3** Install the O-ring assembly on the DP. (See [Figure 13](#) on page 114.)
- 4** Lift the DP into its normal position.
- 5** Install the KF50 clamp.
- 6** Reconnect the DP temperature sensor wires to the wiring harness.
- 7** Reconnect the high vacuum power cable to the HIVAC POWER connector on the back panel of the MSD. This is the thick black cable that emerges near the bottom of the pump.
- 8** Reconnect the foreline gauge fitting to the outlet of the DP.  
If you disconnected the foreline gauge cable, reconnect it to the foreline gauge.
- 9** Move the MSD back to its normal position.

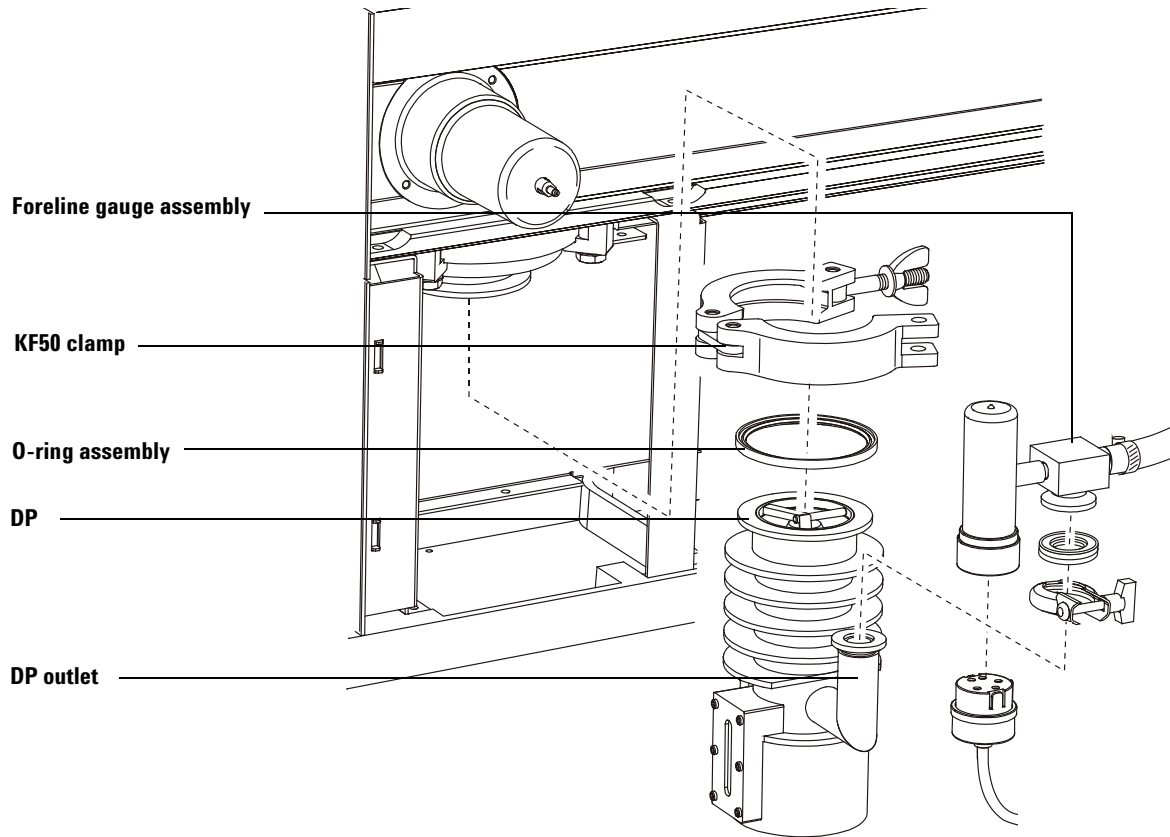

Figure 13 Installing the DP

## To Remove the Foreline Gauge



### Materials needed

- Screwdriver, flat-blade, large (8730-0002)

### Procedure

- 1 Vent the MSD.
- 2 Separate the MSD from the GC and disconnect the transfer line temperature sensor. (See [“To Separate the MSD from the GC”](#) on page 94.)

### WARNING

The foreline pump and DP may still be hot.

- 
- 3 Unplug the foreline gauge cable from the foreline gauge.
  - 4 Disconnect the foreline gauge assembly from the DP outlet.
  - 5 Loosen the hose clamp.

### CAUTION

Ensure the MSD is vented to atmosphere before breaking the seal at the foreline gauge. **Never** vent the MSD at the pump end; use the vent valve.

- 
- 6 Pull the foreline gauge assembly out of the foreline hose. (See [Figure 14](#) on page 116.)



**Figure 14** Foreline gauge assembly



## To Install the Foreline Gauge



### Materials needed

- Foreline gauge assembly (G1099-60545)
- Screwdriver, flat-blade, large (8730-0002)

### Procedure

- 1 Connect a new foreline gauge assembly to the foreline hose.
- 2 Tighten the hose clamp.
- 3 Connect the foreline gauge assembly to the DP outlet.
- 4 Connect the foreline gauge cable to the foreline gauge.
- 5 Reconnect the MSD to the GC. (See [“To Reconnect the MSD to the GC”](#) on page 98.)
- 6 If necessary, slide the foreline pump back under the analyzer chamber. The foreline pump may be located on the floor, on the lab bench next to or behind the MSD, or under the analyzer chamber at the back of the MSD.
- 7 Pump down the MSD.

## To Refill the EI Calibration Vial



### Materials needed

- PFTBA (05971-60571)

### Procedure

- 1 Stop any tuning or data acquisition.
- 2 Turn off the analyzer.
- 3 If your MSD is equipped with a vacuum gauge, turn off the gauge.
- 4 Remove the analyzer window cover.
- 5 Loosen the calibration vial collar. (See [Figure 15](#).) Do not remove the collar.
- 6 Pull the calibration vial out. You may feel some resistance due to residual vacuum.

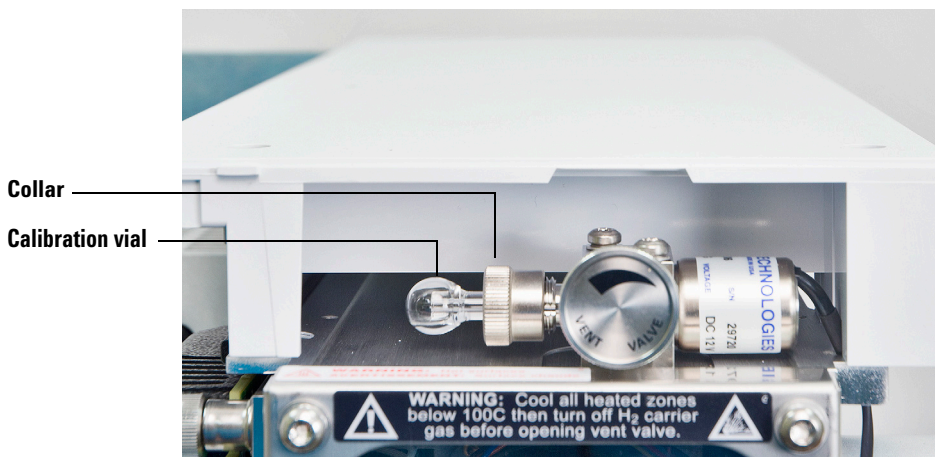

**Figure 15** Removing the EI calibration vial

- 7 Syringe or pipette PFTBA into the vial. With the vial vertical, the liquid should be just below the end of the internal tube, approximately 70  $\mu$ L of sample.
- 8 Push the calibration vial into the valve as far as possible.

- 9 Withdraw the vial 1 mm. This prevents damage when you tighten the collar.
- 10 Turn the collar clockwise to tighten it.

The collar should be snug but not overly tight. Do **not** use a tool to tighten the collar. It does not require that much force.
- 11 Reinstall the analyzer window cover.
- 12 Purge the EI calibration valve. (See [“To Purge the Calibration Valves”](#) on page 120.)

**CAUTION**

Failure to purge the calibration valve will result in damage to the filaments and detector.

---

## To Purge the Calibration Valves

### CAUTION

After removing a calibrant vial, you **must** purge the calibration valve. Failure to do so will result in damage to the filaments and the electron multiplier.

---

#### El calibration valve

After adding new PFTBA to the calibrant vial, you must purge the air out of the vial and valve.

- 1 If the vacuum gauge controller is on, turn it off.
- 2 In **Tune and Vacuum Control** view, select **Purge Calibrant Valve** under the Vacuum menu.

This will open the CI calibration valve for several minutes with all analyzer voltages turned off.

#### CI calibration valve

After adding new PFDTD to the calibrant vial, you must purge the air out of the vial and valve.

- 1 If the vacuum gauge controller is on, turn it off.
- 2 Verify that **PCICH4.U** is loaded.
- 3 In **Tune and Vacuum Control** view, select **Purge Calibrant Valve** under the Vacuum menu.

This will open the CI calibration valve for several minutes with all analyzer voltages turned off.

## To Remove the EI Calibration and Vent Valve Assembly

### Materials needed

- Screwdriver, Torx T-20 (8710-1615)



### Procedure

- 1 Vent the MSD.
- 2 Trace the calibration valve cable to the connector next to the fan, and disconnect it.
- 3 Loosen the collar, and remove the calibration vial. (See [Figure 15](#) on page 118.) Just loosen the collar, do not remove it.

### CAUTION

Removing the valve with the vial installed can result in liquid calibrant getting into the restrictor of the valve. Liquid in the restrictor will prevent diffusion of PFTBA into the analyzer chamber for tuning. Replace the valve if this happens.

---

- 4 Remove the two screws holding the valve assembly to the top of the analyzer chamber. Do not lose the O-ring under it.

## To Install the EI Calibration and Vent Valve Assembly



### Materials needed

- Calibration valve
  - Diffusion (G7077-60211)
  - Turbo (G7077-60204)
- O-ring for calibration valve (0905-1217)
- PFTBA (05971-60571) or other tuning compound
- Screwdriver, Torx T-20 (8710-1615)

### Procedure

- 1 Remove the old valve assembly. (See [“To Remove the EI Calibration and Vent Valve Assembly”](#) on page 121 and [Figure 15](#) on page 118.)
- 2 Ensure the valve O-ring is in place. If it is worn or damaged, replace it.
- 3 Install the calibration and vent valve assembly, and tighten the screws that hold it in place.
- 4 Reconnect the calibration valve cable to the connector next to the fan.
- 5 Remove the vial from the new calibration valve. (See [“To Refill the EI Calibration Vial”](#) on page 118.) The valve is supplied with a vial already installed.
- 6 Fill and reinstall the calibration vial.
- 7 Pump down the MSD.

### CAUTION

Failure to purge the calibration valve will damage the filaments and detector.

## To Replace the Fan for the High Vacuum Pump



### Materials needed

- Fan (G7005-60564)
- Screwdriver, Torx T-20 (8710-1615)

### Procedure

- 1 Vent the MSD.
- 2 Remove the left side MSD cover.
- 3 Disconnect the fan wiring from the connector on the MSD frame. (See [Figure 16](#) on page 124.)
- 4 Remove the four fan screws and the safety grill. Remove the fan. Keep the screws.

### WARNING

Do not touch the high vacuum pump. The pump could still be hot enough to burn you.

---

- 5 Install the new fan with the flow arrow on the side pointing toward the pump. The wires should be at the upper left, close to the connector.
- 6 Add the safety grill and the four screws. Tighten the screws firmly.

### WARNING

Ensure the safety grill that shields the fan blades is in place.

---

- 7 Connect the fan wiring to the fan connector on the MSD frame.
- 8 Reinstall the MSD covers.
- 9 Pump down the MSD.

## 4 General Maintenance

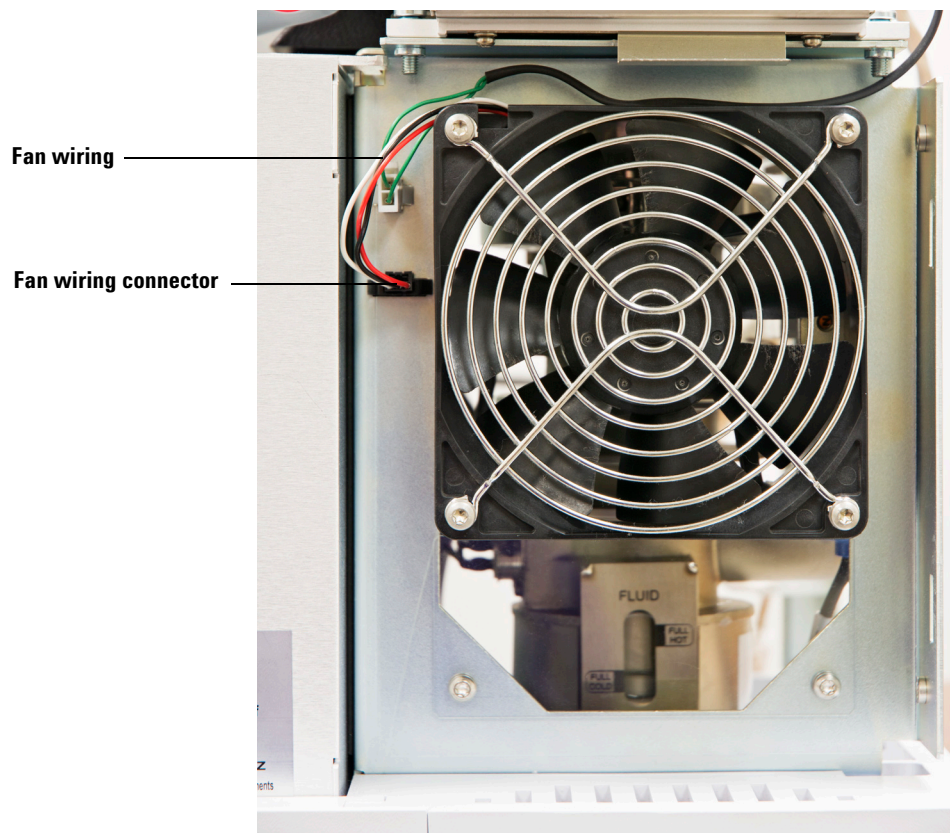

**Figure 16** Replacing the pump fan (DP shown)



## To Remove the Ion Vacuum Gauge



### Procedure

- 1 Vent the MSD.
- 2 Disconnect the cable on the back of the ion vacuum gauge.
- 3 Unscrew the red plastic thumbnut on the gauge clamp.
- 4 Remove the long screw from the clamp.
- 5 While supporting the gauge body, remove the clamp from the mounting flange.
- 6 Remove the gauge.
- 7 If you will not be replacing the gauge soon, install the blanking plate provided with the gauge and secure it with the clamp, screw, and thumbnut.

## To Install an Ion Vacuum Gauge



### Material needed

- KF16 O-ring 0905-1463

### Procedure

- 1 Place the KF16 O-ring in the groove on the analyzer chamber flange. Replace it if it is worn or damaged.
- 2 Hold the gauge flange against the chamber flange with the O-ring. Push the clamp over both flanges.
- 3 Insert the long screw, add the thumbnut, and tighten.
- 4 Attach the communication cable to the back of the gauge and connect the other end to the back of the MS.

## To Lubricate the Side Plate O-Ring



### Materials needed

- Cloths, clean (05980-60051)
- Gloves, clean, lint-free
  - Large (8650-0030)
  - Small (8650-0029)
- Grease, Apiezon L, high vacuum (6040-0289)

The side plate O-ring needs a thin coat of grease to ensure a good vacuum seal. If the side plate O-ring appears dry or does not seal correctly, lubricate it using this procedure. A good test is to wipe off the side plate with methanol, then close the analyzer chamber. If the O-ring has enough grease on it, it will leave a faint trace on the side plate.

### CAUTION

Vacuum seals other than the side plate O-ring and vent valve O-ring do not need to be lubricated. Lubricating other seals can interfere with their correct function.

### Procedure

- 1 Vent the MSD.
- 2 Open the analyzer chamber.
- 3 Use a clean, lint-free cloth or glove to spread a **thin** coat of high vacuum grease only on the exposed surface of the O-ring. (See [Figure 17](#) on page 128.)

### CAUTION

Do not use anything except the recommended vacuum grease. Excess grease can trap air and dirt. Grease on the surface of the O-ring other than the exposed surface can trap air, resulting in air spikes during operation.

- 4 Use a clean, lint-free cloth or glove to wipe away excess grease. If the O-ring looks shiny, there is too much grease on it.
- 5 Close the analyzer chamber.
- 6 Pump down the MSD.

## 4 General Maintenance

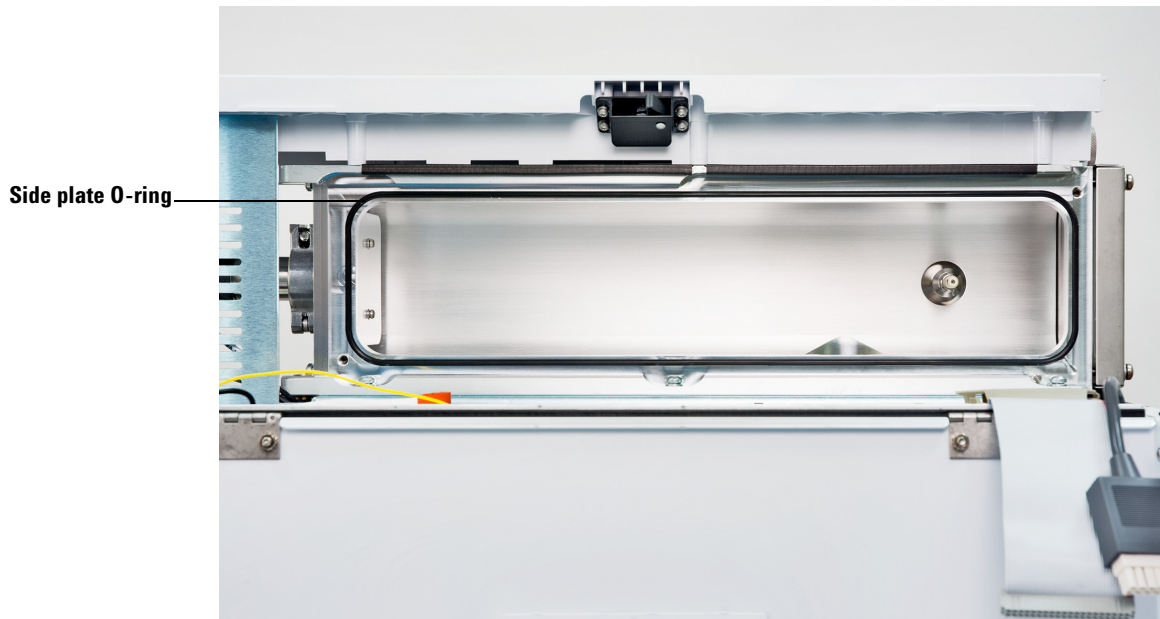

**Figure 17** Side plate O-ring

## To Lubricate the Vent Valve O-Ring



### Materials needed

- Cloths, clean (05980-60051)
- Gloves, clean, lint-free
  - Large (8650-0030)
  - Small (8650-0029)
- Grease, Apiezon L, high vacuum (6040-0289)
- O-ring, vent valve (0905-1217). Replace if the old O-ring is worn or damaged

The vent valve O-ring needs a thin coat of lubrication to ensure a good vacuum seal and smooth operation. If the vent valve O-ring does not turn smoothly or does not seal correctly, lubricate it using this procedure.

### CAUTION

Vacuum seals other than the side plate O-ring and vent valve O-ring do not need to be lubricated. Lubricating other seals can interfere with their function.

### Procedure

- 1 Vent the MSD.
- 2 Completely remove the vent valve knob. (See [Figure 18](#) on page 130)
- 3 Inspect the O-ring. If the O-ring appears damaged, replace it.
- 4 Use a clean, lint-free cloth or glove to spread a *thin* coat of high vacuum grease on the exposed surface of the O-ring.

### CAUTION

Excess grease can trap air and dirt. Grease on surfaces of the O-ring other than the exposed surface can trap air, resulting in air spikes during operation.

- 5 Use a clean, lint-free cloth or glove to wipe away excess grease. If the O-ring looks shiny, there is too much grease on it



**Figure 18** Vent valve O-ring

- 6 Reinstall the vent valve knob.

### CAUTION

Be very careful when reinstalling the vent valve knob. It is possible to cross thread the knob and damage the threads in the valve body. Ensure the O-ring stays in place.

- 7 Pump down the MSD.

## Maintaining the Electronics

### Scheduled maintenance

None of the electronic components of the MSD need to be replaced on a regular schedule. None of the electronic components in the MSD need to be adjusted or calibrated on a regular schedule. Avoid unnecessary handling of the MSD electronics.

### Electronic components

Very few of the electronic components are operator serviceable. The primary fuses can be replaced by the operator. The RF coils can be adjusted by the operator. All other maintenance of the electronics should be performed by your Agilent Technologies service representative.

---

**WARNING**

**Improper use of these procedures could create a serious safety hazard. Improper use of these procedures could also result in serious damage to, or incorrect operation of, the MSD.**

---

**WARNING**

**Vent the MSD and disconnect its power cord before performing any of these procedures *except* adjusting the RF coils.**

---

### Electrostatic precautions

All of the printed circuit boards in the MSD contain components that can be damaged by electrostatic discharge (ESD). Do not handle or touch these boards unless absolutely necessary. In addition, wires, contacts, and cables can conduct ESD to the printed circuit boards to which they are connected. This is especially true of the mass filter (quadrupole) contact wires which can carry ESD to sensitive components on the side board. ESD damage may not cause immediate failure, but it will gradually degrade the performance and stability of your MSD.

When you work on or near printed circuit boards, or when you work on components with wires, contacts, or cables connected to printed circuit boards, always use a grounded antistatic wrist strap and take other antistatic

precautions. The wrist strap should be connected to a known good earth ground. If that is not possible, it should be connected to a conductive (metal) part of the assembly being worked on, but **not** to electronic components, exposed wires or traces, or pins on connectors.

Take extra precautions, such as a grounded antistatic mat, if you must work on components or assemblies that have been removed from the MSD. This includes the analyzer.

### CAUTION

To be effective, an antistatic wrist strap must fit snugly (not tight). A loose strap provides little or no protection.

---

### CAUTION

Antistatic precautions are not 100% effective. Handle electronic circuit boards as little as possible and then only by the edges. Never touch the components, exposed traces, or pins on connectors and cables.

---

### More information is available

More information about the functions of electronic components section is found later in this manual. (See [Chapter 8](#), “[Electronics](#)” on page 199.)

Most of the procedures in this chapter are illustrated with video clips.



## To Adjust the Quad Frequency



### Materials needed

- Screwdriver, flat-blade, large (8730-0002)

### Procedure

- 1 Ensure the MSD is at thermal equilibrium. It takes at least 2 hours *after* all heated zones have reached their setpoints for the MSD to reach thermal equilibrium.
- 2 Open the analyzer cover.

### WARNING

**Do not remove any other covers. Dangerous voltages are present under these covers.**

---

- 3 Ensure the RF cover on the side board is secure and no screws are missing. A loose RF cover or missing screw can *significantly* affect coil adjustment.
- 4 In the **Tune and Vacuum Control** view, select **Optimize Quadrupole Frequency** from the Execute menu.
- 5 Enter an  $m/z$  value of 100.
- 6 Slowly turn the quad frequency adjustment screws to minimize the voltage displayed. (See [Figure 19](#) on page 134.)

Turn the adjustment screws alternately. Turn each screw only a little bit at a time. Keep the screws at *equal* extension.

### CAUTION

Do not use a coin to adjust the screws. If you drop it, it could fall into the electronics fan and cause significant damage.

---

- 7 When the voltage is minimized, click **Stop**.

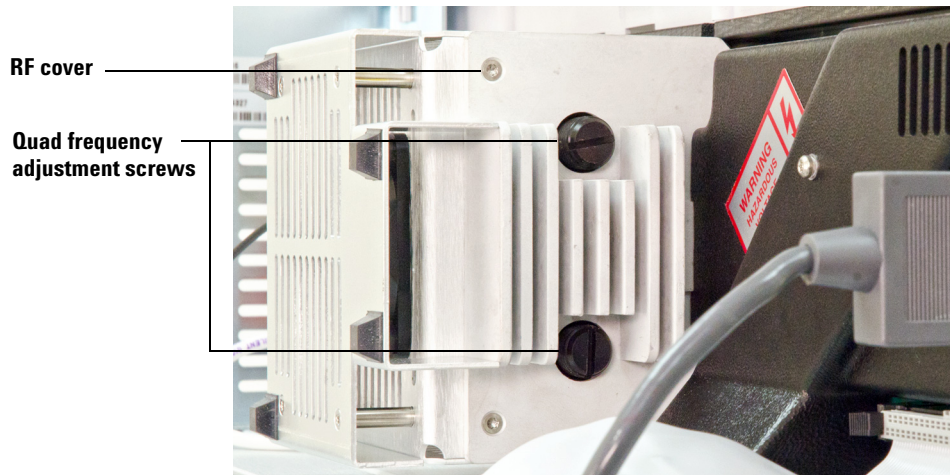

**Figure 19** Adjusting the quad frequency

- 8 Repeat steps 4 through 7 for  $m/z$  650.
- 9 Exit the Set Optimize Quadrupole Frequency program.
- 10 Select **MS OFF** from the Execute menu.
- 11 Close the analyzer cover.
- 12 Tune the MSD.

## To Replace the Primary Fuses

### Materials needed

- Fuse, T12.5A, 250 V (2110-1398) – two required
- Screwdriver, flat-blade (8730-0002)

The most likely cause of failure of the primary fuses is a problem with the foreline pump. If the primary fuses in your MSD fail, check the foreline pump.

### Procedure

- 1 Vent the MSD, and unplug the power cord from the electrical outlet.

If one of the primary fuses has failed, the MSD will already be off, but for safety you should switch off the MSD, and unplug the power cord. It is not necessary to allow air into the analyzer chamber.

---

**WARNING**

**Never replace the primary fuses while the MSD is connected to a power source.**

---

**WARNING**

**If you are using hydrogen as a GC carrier gas, a power failure may allow it to accumulate in the analyzer chamber. In that case, further precautions are required. (See “Hydrogen Safety” on page 22.)**

- 2 Turn one of the fuse holders counterclockwise until it pops out. (See [Figure 20](#) on page 136.) The fuse holders are spring loaded.
- 3 Remove the old fuse from the fuse holder.
- 4 Install a new fuse in the fuse holder.
- 5 Reinstall the fuse holder.

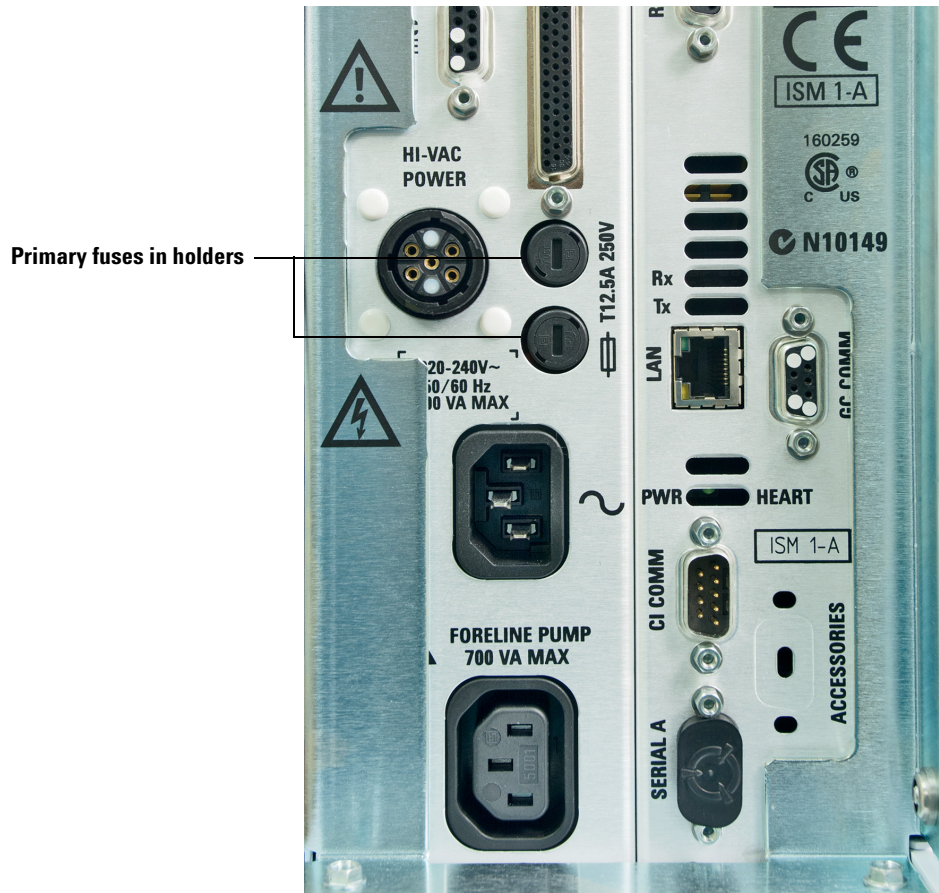

**Figure 20** Primary fuses (turbo model shown)

- 6 Repeat steps 2 through 5 for the other fuse. Always replace both fuses.
- 7 Reconnect the MSD power cord to the electrical outlet.
- 8 Pump down the MSD.

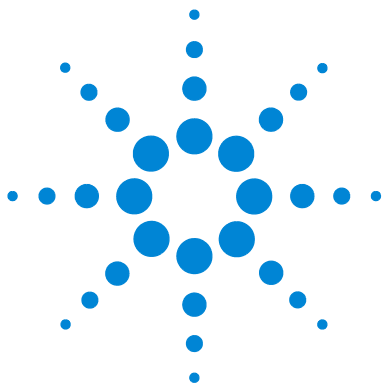

## 5 CI Maintenance

To Replace the Methane/Isobutane Gas Purifier 138

To Clean the Reagent Gas Supply Lines 139

To Refill the CI Calibrant Vial 140

This chapter describes maintenance procedures and requirements that are unique to 5977B Series MSDs equipped with the CI hardware.



## To Replace the Methane/Isobutane Gas Purifier



### Materials needed

- Methane/Isobutane gas purifier (G1999-80410)
- Front ferrule for 1/8-inch tubing (5180-4110)
- Rear ferrule for 1/8-inch tubing (5180-4116)
- Tubing cutter (8710-1709)

The methane/isobutane gas purifier needs to be replaced after four tanks of reagent gas. This frequency may vary depending on purity of the gas and care taken in uncapping and installing the gas purifier. A large leak upstream from the gas purifier can quickly exhaust the reduced metal of the oxygen and moisture traps.

### Procedure

- 1 To install the methane/isobutane gas purifier, follow the instructions on the label for installation and replacement intervals.

### CAUTION

Do not remove the caps until you are ready to install the gas purifier. Only remove the caps in the gas flow to prevent contamination by air.

---

### WARNING

**Methane is flammable. Extinguish all flames in the area before turning on gas flow.**

---

- 2 Disconnect the fittings on the old filter.
- 3 Remove the ferrules from the tubing at the outlet of the gas purifier. Using the tubing cutter, cut off the end of the tubing with the ferrules.
- 4 Install the new filter.
- 5 Purge the new filter.
- 6 Cap the old filter and prepare it to be sent for regeneration. See the instructions on the label.

## To Clean the Reagent Gas Supply Lines

### Materials needed

- Clean, dry nitrogen
- Heat gun
- Tubing cutter (8710-1709)

### Procedure

If the reagent gas lines become contaminated, they can be cleaned.

- 1 Disconnect the reagent gas tubing from the gas supply, the gas purifier, and the MSD.
- 2 Cap the gas purifier following the instructions on the label.
- 3 Connect one end of the tubing to a supply of clean, dry nitrogen and turn on the gas flow.
- 4 Use the heat gun to warm the tubing, starting at the supply end and working your way to the free end.
- 5 Repeat for any other pieces of tubing that need to be cleaned.
- 6 Reconnect the tubing to the gas supply, gas purifier, and MSD. Follow the instructions on the gas purifier label.

---

**WARNING**

**Do not heat the gas tubing when reagent gas is flowing.**

---

**CAUTION**

Do not put liquids into the tubing. Do not heat the tubing when it is connected to the MSD.

---

## To Refill the CI Calibrant Vial



### Materials needed

- PFDTD calibrant (8500-8510)

### Procedure

- 1 Set the reagent gas flow to **Gas Off**.
- 2 Vent the MSD.
- 3 Remove the capillary column from the GC/MSD interface.
- 4 Pull the MSD away from the GC to expose the calibration vial and valve. (See [“To Separate the MSD from the GC”](#) on page 94.)
- 5 Loosen the collar holding the calibration vial in place. Do not remove the collar.
- 6 Remove the calibrant vial. (See [Figure 21](#) on page 141.)

### CAUTION

Do **not** rinse the vial with any solvents. **Never** expose the inside of the vial to chlorinated solvents or isopropyl alcohol or water — this will result in severe loss of CI sensitivity.

---

- 7 Fill the vial no higher than the bottom of the internal tube with fresh PFDTD calibrant (8500-8510).
- 8 Replace the vial and tighten the collar.
- 9 Reposition the MSD next to the GC. (See [“To Reconnect the MSD to the GC”](#) on page 98.)
- 10 Reinstall the capillary column.
- 11 Pump down the MSD.
- 12 Purge the calibration valve. (See [“To Purge the Calibration Valves”](#) on page 120.)

### CAUTION

After removing the calibrant vial, you **must** purge the calibration valve. Failure to do so will result in severe contamination of the ion source and damage to the filament and electron multiplier.

---



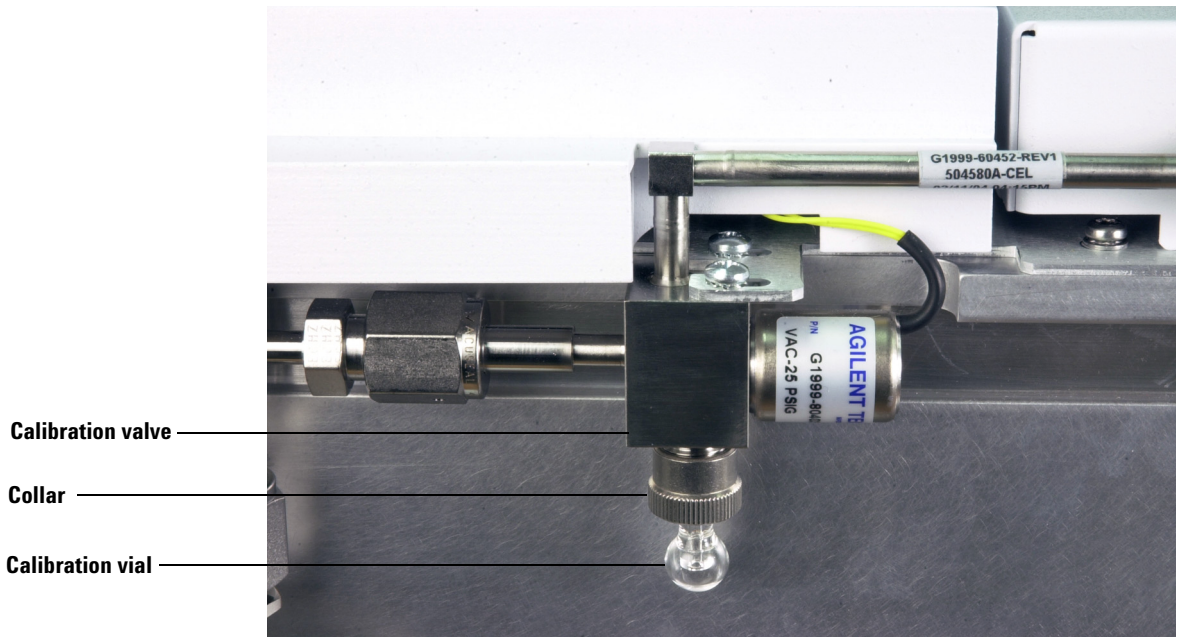

**Figure 21** CI calibration valve and vial



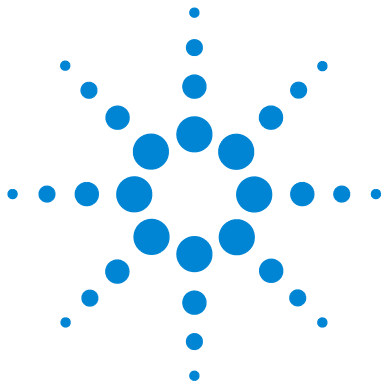

## 6 Vacuum System

Overview	144
Vacuum System Components	145
Common Vacuum System Problems	146
Foreline Pump	147
High Vacuum Pump	151
Analyzer Chamber	152
Side Plate	153
Vacuum Seals	156
Foreline Gauge	158
DP and Fan	159
Turbo Pump and Fan	165
Calibration Valves and Vent Valve	166
Micro-Ion Vacuum Gauge	169

This chapter describes components of the MSD vacuum system.



## Overview

The vacuum system creates the high vacuum (low pressure) required for the MSD to operate. Without the vacuum, the molecular mean free path would be very short and ions would collide with air molecules before they could reach the detector. Operation at high pressures also would damage analyzer components.

The 5977B Series MSDs use two vacuum pumps to obtain the vacuum levels needed. One of two foreline pumps (standard or dry) creates a low vacuum, then a high vacuum pump engages to create the vacuum needed for operation. The 5977B Series MSD uses one of two kinds of high vacuum pumps: a DP or a Turbo pump. The pump type determines the maximum column flow supported by the MSD.

**Table 10** Recommended maximum flow rates by model

<b>Model number</b>	<b>Description</b>	<b>Maximum recommended column flow</b>
G7080B	DP, EI	1.5 mL/min
G7077B	Turbo pump, EI	4.0 mL/min
G7078B	Turbo pump, EI	4.0 mL/min
G7081B	Turbo pump, EI	4.0 mL/min
G7079B	Turbo pump, EI	4.0 mL/min

Most vacuum system operation is automated. Operator interaction is through the DS or control panel. Monitor the vacuum system through the DS or GC control panel.

## Vacuum System Components

The parts of the vacuum system are: (See [Figure 22.](#))

- Foreline (rough) pump
- High vacuum pump (diffusion or turbo pump)
- Analyzer chamber
- Side plate (analyzer door), and front and rear end plates
- Vacuum seals
- Calibration valve(s) and vent valve
- Vacuum control electronics
- Vacuum gauges and gauge control electronics

Each of these is discussed in more detail in this chapter.

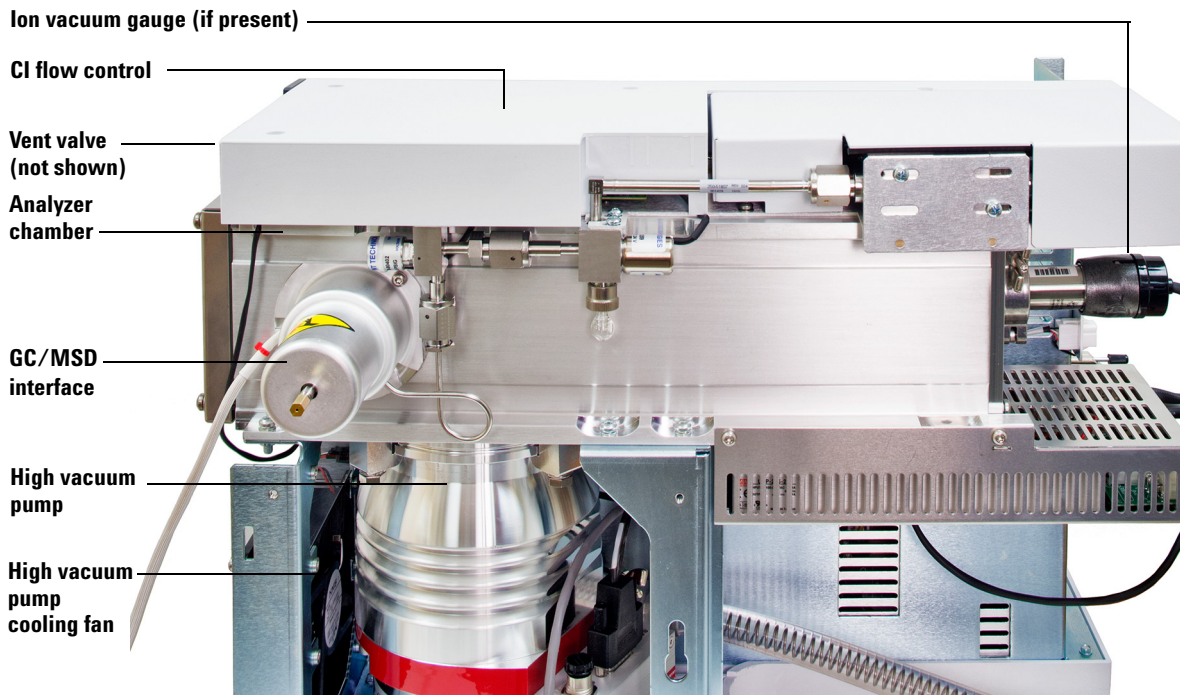

**Figure 22** Example vacuum system components (MSD with turbo pump shown)

## Common Vacuum System Problems

### Air leak symptoms

The most common problems associated with any vacuum system are air leaks. Symptoms of air leaks include:

- Loud gurgling noise from the foreline pump (very large leak)
- Inability of the turbo pump to reach 95% speed
- High foreline pressure in DP MSDs
- Higher than normal high vacuum gauge controller readings

The 5977B Series MSD will **not** pump down successfully unless you press on the side plate (analyzer door) when you turn on the MSD power. Continue to press until the sound from the foreline pump becomes quieter.

### Pumpdown failure shutdown

The system will shut down both the high vacuum and the foreline pump if the system fails to pump down correctly. Two conditions that trigger shutdown are:

- DP MSDs, shutdown occurs if the foreline pressure is above 300 mTorr after 7 minutes.
- Turbo pump MSDs speed below 80% after 7 minutes.

This is usually because of a **large** air leak: either the side plate has not sealed correctly or the vent valve is still open. This feature helps prevent the foreline pump from sucking air through the system, which can damage the analyzer and pump.

To restart the MSD, find and correct the air leak, then switch the power off and on. Press on the side plate when turning on the MSD power to ensure a good seal.

## Foreline Pump

The foreline pump reduces the pressure in the analyzer chamber so the high vacuum pump can operate. It also pumps away the gas load from the high vacuum pump. The foreline pump is connected to the high vacuum pump by a 130-cm hose called the foreline hose. There are four different types of foreline pumps, the Pfeiffer DUO (See [Figure 23.](#)), the MVP-070-3 (See [Figure 24](#) on page 148.), the MVP-070-3C (not shown), and the IDP3 (See [Figure 25](#) on page 148.). The dry foreline pumps are not supported with DP base MSDs.

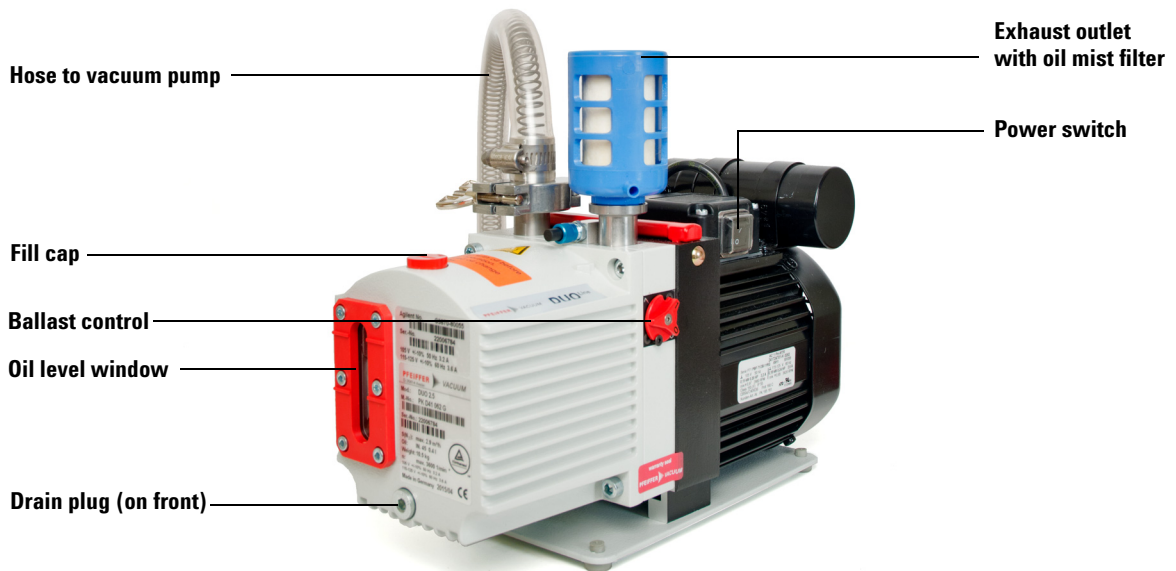

**Figure 23** Pfeiffer DUO foreline pump

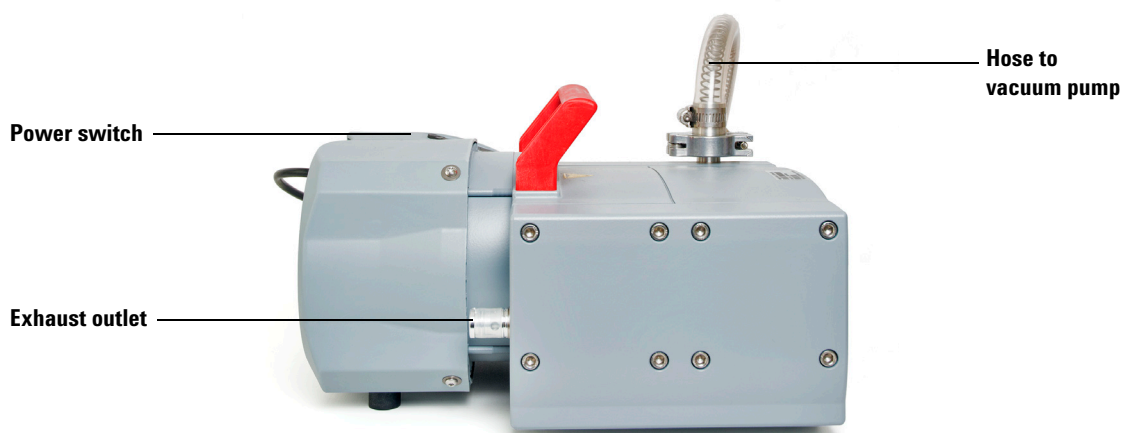

Figure 24 MVP-070-3 dry foreline pump



Figure 25 IDP3 dry foreline pump

**CAUTION**

Agilent does not recommend using hydrogen as a carrier gas on systems equipped with an IDP3 rough pump.



The standard foreline pump is a two-stage rotary-vane pump. An optional dry pump is also available. The pump turns on when the MSD power is turned on. The foreline pump has a built-in antisuckback valve to help prevent backstreaming in the event of a power failure.

The foreline pump can be placed under the analyzer chamber at the rear of the MSD (with the exhaust outlet to the rear) or on the floor below the MSD.

An oil trap (not shown) is available for the standard pump that can be used to filter pump oil out of the foreline pump exhaust. This trap stops *only* pump oil. Do not use the trap if you are analyzing toxic chemicals or using toxic solvents or if you have a CI MSD. Instead, install an 11-mm id hose to remove the exhaust from your lab.

**WARNING**

**The oil trap supplied with the standard foreline pump stops only foreline pump oil. It does not trap or filter out toxic chemicals. If you are using toxic solvents or analyzing toxic chemicals, remove the oil trap. Do not use the trap if you have a CI MSD. Install a hose to take the foreline pump exhaust outside or to a fume hood.**

---

**CAUTION**

Do not place the foreline pump near any equipment that is sensitive to vibration.

---

**CAUTION**

The ballast control knob controls the amount of air allowed into the pump. Keep the ballast control closed (fully clockwise) at all times, except when ballasting the pump.

---

A window (sight glass) in the front of the standard foreline pump shows the level of the foreline pump oil. There are two marks next to the window. The level of the pump oil should never be above the upper mark or below the lower mark. If the level of pump oil is near the lower mark, add foreline pump oil.

### **The oil pan under the foreline pump can be a fire hazard (standard pump)**

Oily rags, paper towels, and similar absorbents in the oil pan could ignite and damage the pump and other parts of the MSD.

**WARNING**

**Combustible materials (or flammable/nonflammable wicking material) placed under, over, or around the foreline (roughing) pump constitutes a fire hazard. Keep the pan clean, but do not leave absorbent material such as paper towels in it.**

---

## High Vacuum Pump

### DP system

The DP supports a maximum flow rate of 1.5 mL/min into the MSD. The DP uses baffling to prevent vapor from migrating into the analyzer chamber. Foreline pressure is monitored by the foreline gauge. The AC board controls the DP heater.

### Turbo pump system

The 5977B Series MSD has one turbo pump. The turbo pump has a screen to keep debris out of the pump, but no baffle is necessary. Pump speed is controlled by the turbo controller; there is no foreline gauge.

## Analyzer Chamber

The analyzer chamber is where the analyzer operates. (See [Figure 26.](#)) The manifold is extruded and machined from an aluminum alloy. Large openings in the side, front, and rear of the analyzer chamber are closed by plates. O-rings provide the seals between the plates and the manifold. Ports in the manifold and the plates provide attachment points for the Micro-Ion vacuum gauge, calibration valve, vent valve, GC/MSD interface, and high vacuum pump.

### DP version

The DP attaches, with a KF50 seal, to a baffle adapter that is clamped to the bottom of the manifold. A vapor baffle helps prevent migration of pump fluid vapor into the manifold. Cooling fins on the bottom of the manifold keep the baffle cool so the vapor will condense on it.

### Turbo pump version

The turbo pump and the mounting bracket for the turbo controller are clamped directly to the manifold.

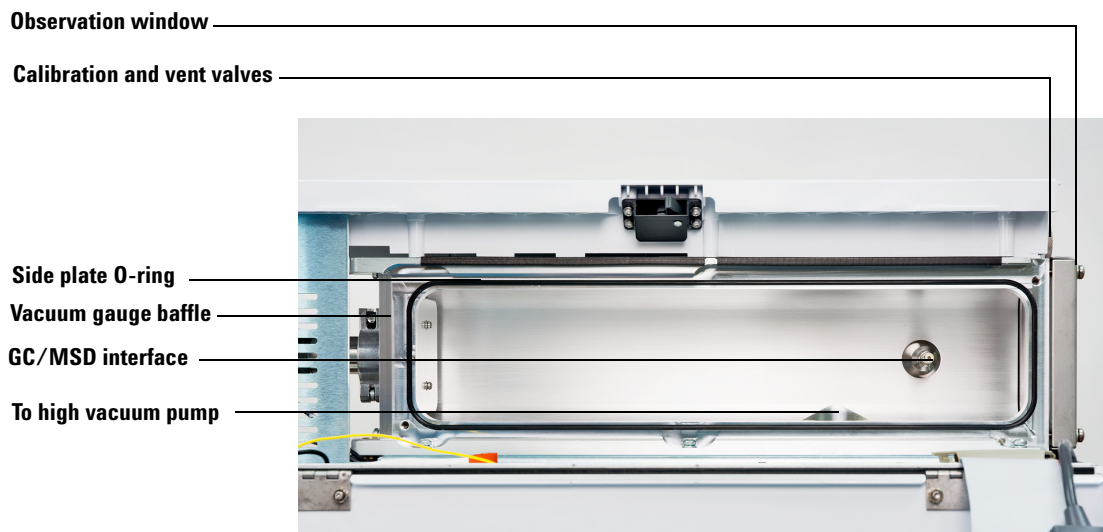

**Figure 26** Analyzer chamber

## Side Plate

The side plate covers the large opening in the side of the analyzer chamber. (See [Figure 27](#) on page 154 for a side plate used with the EI HES source, and [Figure 28](#) on page 155 for a side plate used with other source types.) It is attached to the manifold with a hinge. The analyzer assembly is attached to the side plate inside the analyzer chamber. The hinge allows the side plate to swing away from the manifold for easy access to the analyzer.

Several electrical feedthroughs are built into the side plate. Wires connect the feedthroughs to analyzer components. The electronic side board is mounted on the atmospheric side of the side plate.

Thumbscrews are located at each end of the side plate.

---

**CAUTION**

Fasten both side plate thumbscrews for shipping or storage only. For normal operation, both thumbscrews should be loose. For operation with hydrogen carrier gas, or with flammable or explosive CI reagent gases, the front thumbscrew should be fastened just finger-tight. Overtightening will warp the side plate and cause air leaks. Do not use a tool to tighten the side plate thumbscrews.

---

**CAUTION**

When you turn on the power to pump down the MSD, press on the side board to ensure a good seal.

---

## 6 Vacuum System

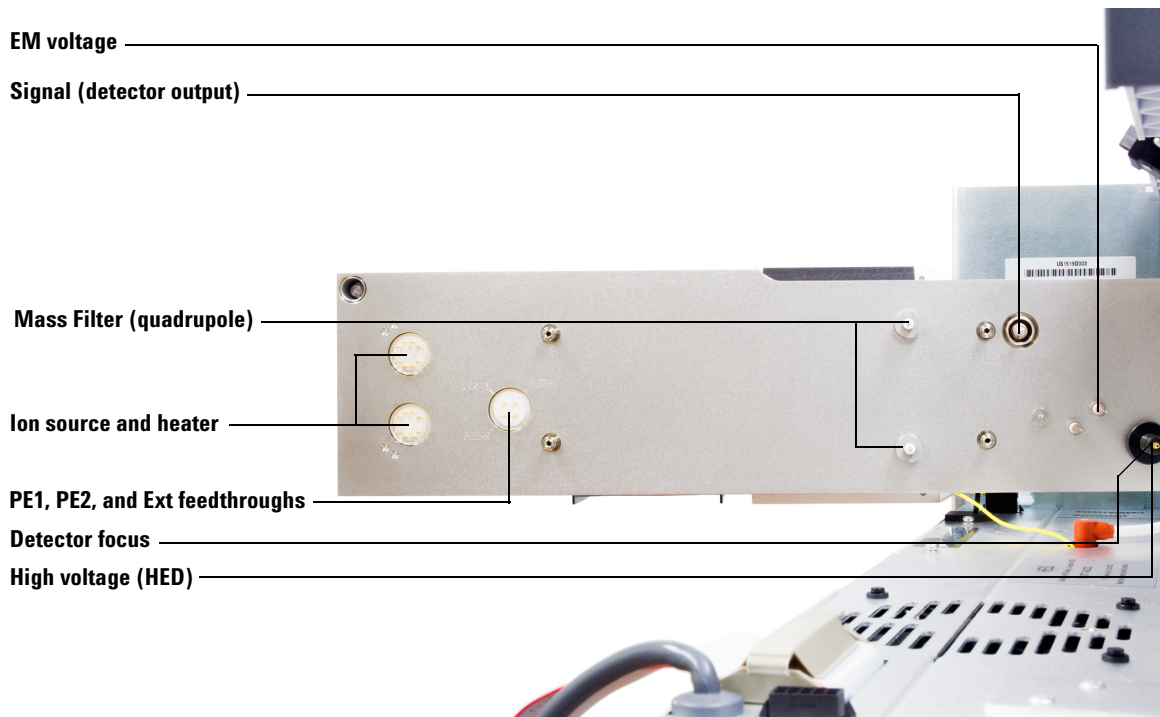

**Figure 27** Side plate feedthroughs

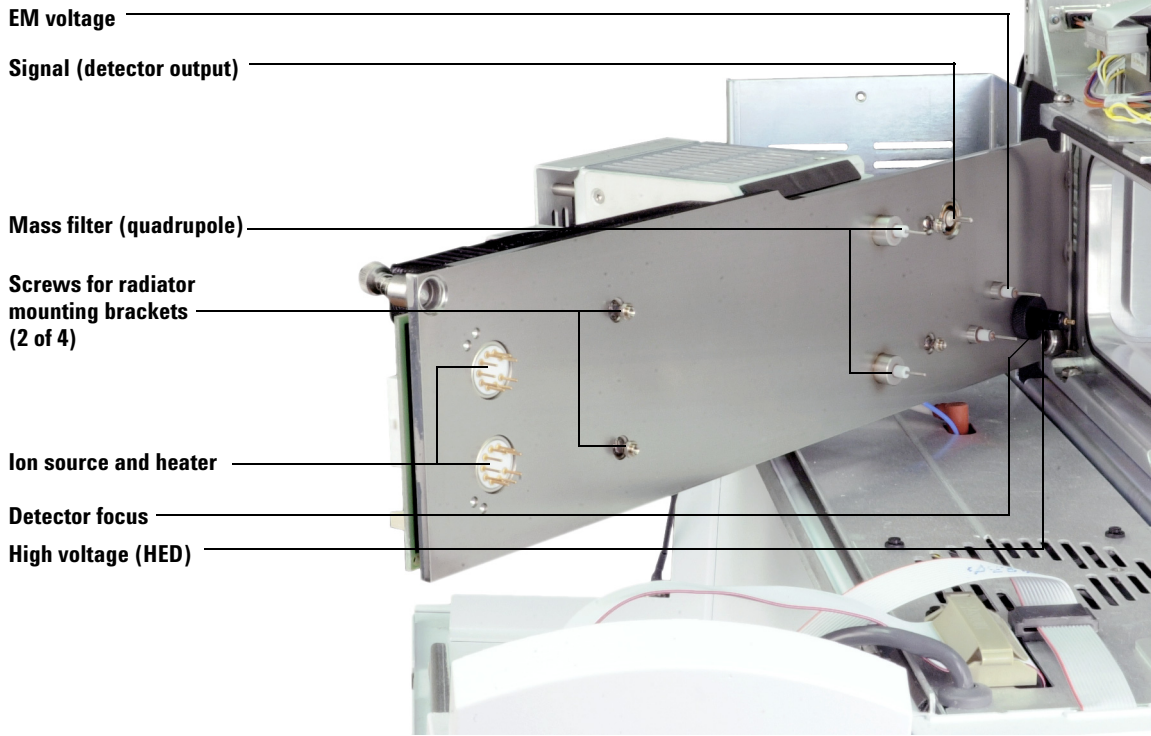

**Figure 28** Side plate feedthroughs

### Vacuum Seals

Several types of Viton elastomer O-ring seals are used to prevent air leaks into the analyzer chamber. (See [Figure 29](#) on page 157.) All these O-rings, and the surfaces to which they seal, must be kept clean and protected from nicks and scratches. A single hair, piece of lint, or scratch can produce a serious vacuum leak. Two of the O-rings, the side plate O-ring and the vent valve O-ring, are *lightly* lubricated with Apiezon-L vacuum grease.

#### Face seals

A face seal is an O-ring that fits in a shallow groove. The sealing surface is usually a flat plate. The manifold side plate and end plate O-rings fit into grooves around the large openings in the analyzer chamber. The side plate swings into place against the side plate O-ring, and must be held in place when the MSD is turned on for pump down to ensure a good seal.

The front and rear end plates are screwed onto the manifold and should not need to be removed. The GC/MSD interface fastens to the manifold with three screws.

The calibration valve assembly is fastened onto the front end plate by two screws. The vent valve knob threads into the front end plate. Small O-rings in grooves in the front end plate provide vacuum seals.

The DP baffle adapter has a groove for its O-ring. The baffle adapter is clamped to the manifold with four claw grips.

#### KF (NW) seals

Most of the seals for the high vacuum pumps, foreline gauge, and foreline pump are KF seals. KF seals have an O-ring supported by a centering ring. The centering ring can be either on the inside or outside of the O-ring. The clamp presses two flanges against the O-ring, making a seal. KF clamps must not be overtightened.



## Compression seals

A compression fitting consists of a threaded fitting on the analyzer chamber and a threaded collar with a ferrule and O-ring. A cylindrical part fits inside the collar. Tightening the collar presses the ferrule, compressing the O-ring around the part. The calibration vials use compression seals.

## High voltage feedthrough seal

The high voltage (HED) feedthrough seal is an O-ring that is compressed against the side plate by a threaded collar.

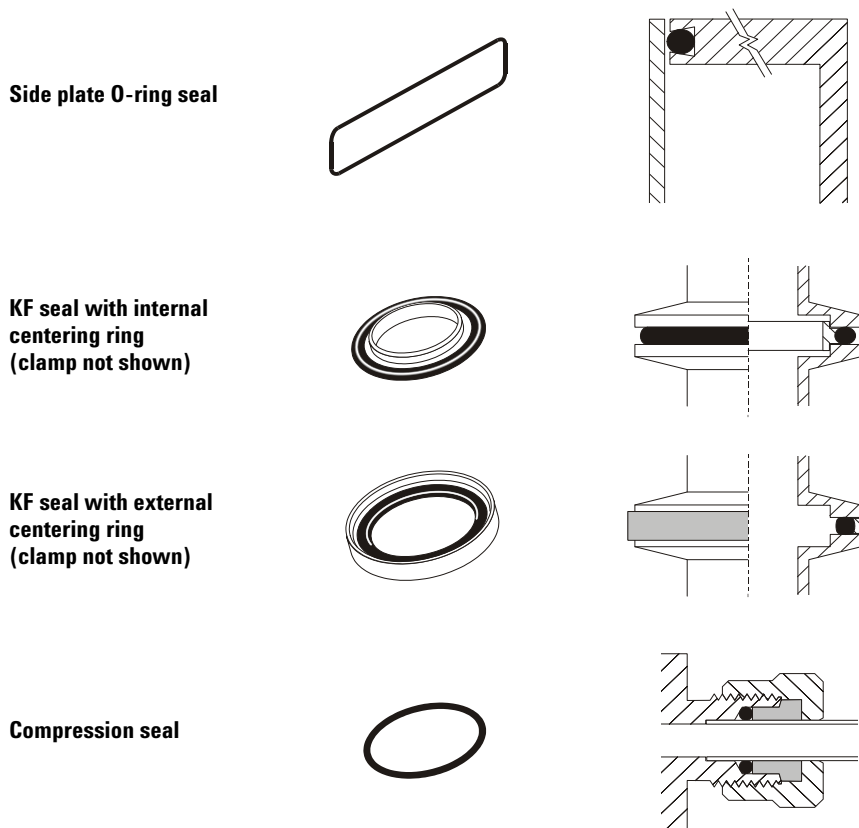

Figure 29 Vacuum seals

### Foreline Gauge

The foreline gauge monitors the pressure (vacuum) at the exit of the DP. The primary function of the foreline gauge is DP control. When the foreline pump has reduced the pressure in the analyzer chamber to below 300 mTorr (0.3 Torr), the DP is automatically switched on. If the foreline pressure rises above 400 mTorr (0.4 Torr), the AC board switches off the DP heater and the analyzer electronics.

Monitor the foreline pressure from the DS or the GC control panel.

The foreline gauge is used only with DP MSDs.

## DP and Fan

The DP in the MSD is an air-cooled vapor DP with 90 L/s capacity. It mounts with a KF50 fitting to a baffle adapter clamped to the bottom of the analyzer chamber.

The DP has a cylindrical body surrounded by fins to help dissipate heat. Its inlet is open to the interior of the analyzer chamber, through the adapter and baffle. A structure called the stack is located at the center of the pump body. An electric heater is located at the bottom of the stack. (See [Figure 30](#) on page 159 and [Figure 31](#) on page 160.)



**Figure 30** DP with fan

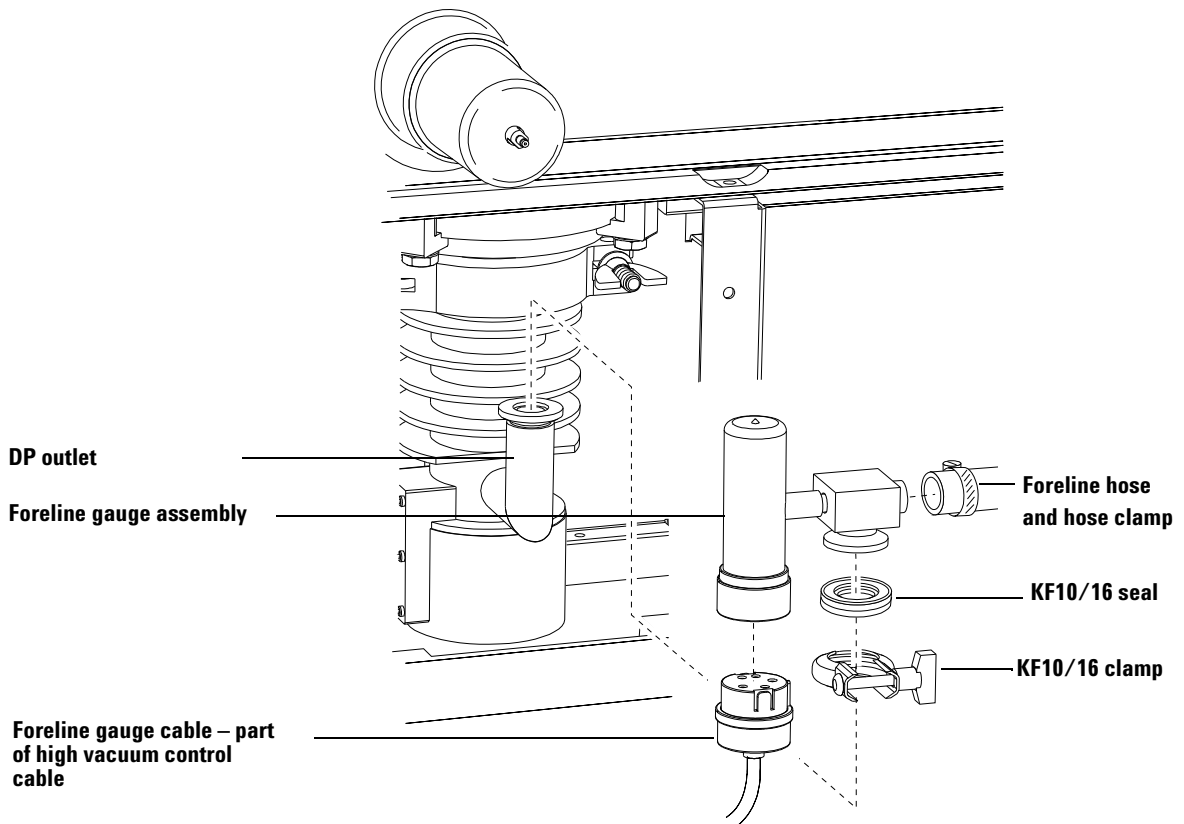

**Figure 31** DP parts

The DP transports gas by momentum transfer. The heater boils a special fluid (a polyphenyl ether) inside the stack. As the vapor pressure increases, the pump fluid vapor is forced out and downward through nozzles in the stack. The vapor forced out of these nozzles strikes the gas molecules that are present. This forces the gas molecules down toward the outlet near the bottom of the pump. Another nozzle in the stack points directly at the outlet, and forces the gas molecules out. The vapor condenses on the sides of the pump, and the liquid drains down to the bottom. The liquid is boiled again, and is reused continuously.

A cooling fan is located between the DP and the front cover of the MSD. The fan draws air through the cover and blows it over the pump. Without this cooling, the pump fluid vapor would not condense correctly, and would diffuse into the analyzer chamber.

The foreline pump is connected by the foreline hose to the outlet of the DP. It removes the gas molecules that reach the outlet.

The DP operation is controlled by the AC board. The AC board automatically turns on the DP heater as soon as the foreline pump lowers the pressure in the analyzer chamber below approximately 300 mTorr (0.3 Torr). Until the foreline pressure drops below 300 mTorr, the DP heater will not turn on. If the pressure does not drop below 300 mTorr within 7 minutes of turning the MSD on, the foreline pump will shut off. During operation, if the foreline pressure rises above 400 mTorr, the DP heater will turn off. The AC board allows the analyzer electronics to turn on when the DP is hot.

The DP typically maintains an indicated pressure below  $1.0 \times 10^{-4}$  Torr for GC helium carrier gas flows up to 2 mL/min. High vacuum (manifold) pressure can only be measured if your MSD is equipped with the optional gauge controller.

The small size of the DP allows it to heat up and cool down quickly. This simplifies pumpdown and venting. From initial power-on, the system can pump down to operating pressure in approximately 15 minutes. If the power fails, the DP fluid stops boiling before the analyzer chamber pressure begins to rise significantly. This helps prevent back diffusion of pump fluid into the analyzer chamber. Your DS has pumpdown and venting programs to guide you through these procedures. Follow the instruction carefully.

Two thermal switches monitor DP operational readiness. (See [Table 11](#).)

**Table 11** DP thermal switches

Thermal switch	Too cold	Too hot
Normal state	Normally open	Normally closed
Changes at	170 °C rising; 140 °C falling	365 °C rising

**Table 11** DP thermal switches (continued)

Function	Keeps analyzer turned off until the pump is hot enough to for adequate vacuum. Prevents analyzer damage	Shuts off DP and analyzer if the pump overheats. Prevents damage to the pump and analyzer.
Message	The high vacuum pump is not ready	Difficulty with the high vacuum pump
What it means	Normal during pumpdown	Always indicates a problem
What to do	Wait for pump to heat up	Check the level and conditions of the fluid. Make sure pump is cool, and power-cycle MSD to reset.

Check the condition and level of the DP fluid through the window (sight glass) near the base of the front of the pump. (See [Figure 32](#) on page 163.) If the level drops below the appropriate marker (there are separate ranges for hot and cold conditions) or if the fluid turns dark brown or black, replace the fluid. Otherwise, replace the fluid once a year.

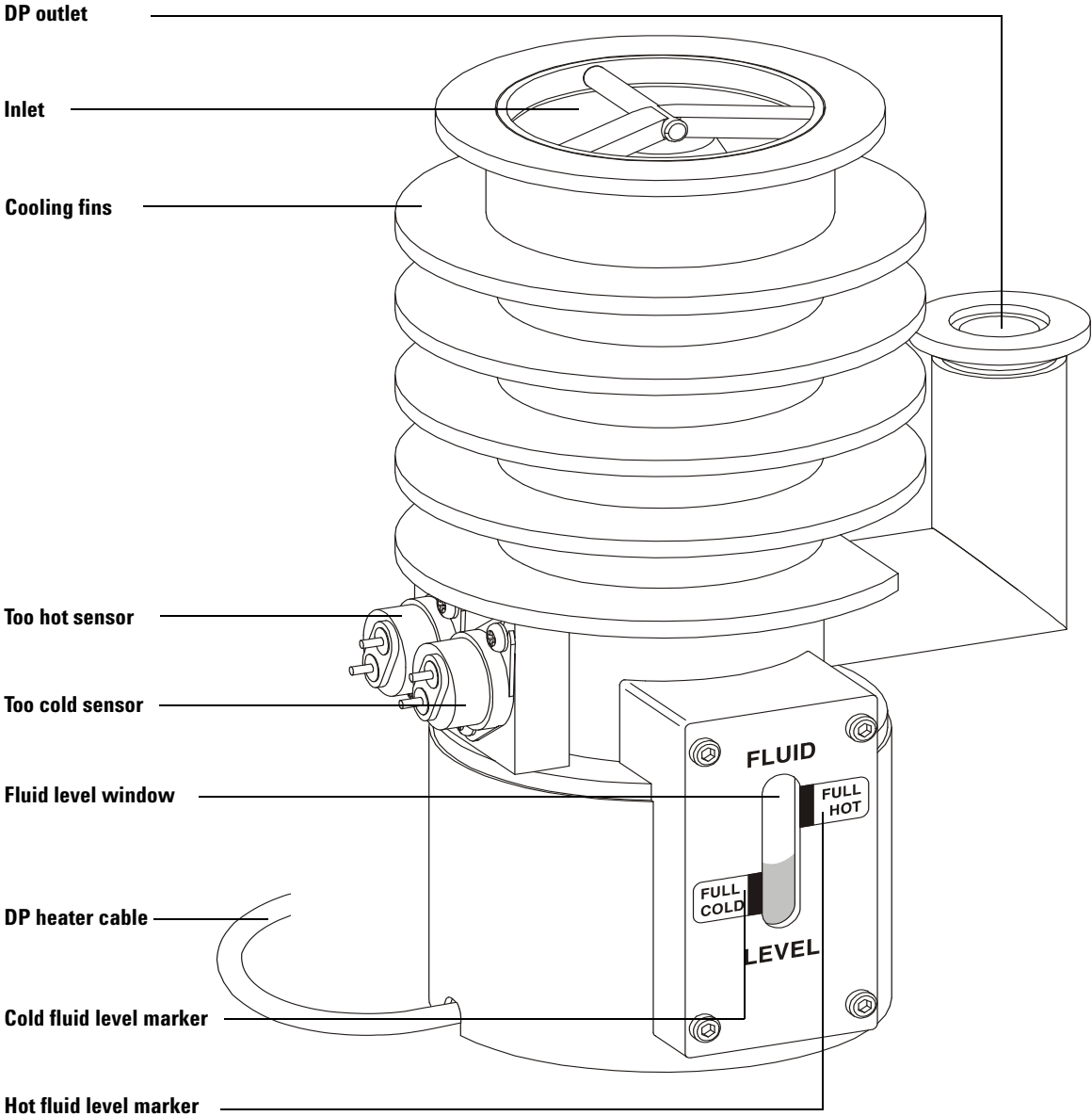

Figure 32 The DP

DP fluid that is exposed to air at operating temperature will break down and turn dark brown or black. This reaction is called cracking. Cracked pump fluid gives two symptoms: higher manifold pressure and high background with a large peak at  $m/z$  446.

### See also

- *“Maintaining the Vacuum System” on page 93.*
- *The troubleshooting sections of the MSD Data Acquisition online help.*



## Turbo Pump and Fan

The turbo pump is clamped directly to the bottom of the analyzer chamber.

The turbo pump has a cylindrical body with its inlet open to the interior of the analyzer chamber. Inside the pump body is a central shaft or cylinder. Sets of small blades (airfoils) radiate from the central shaft. The shaft spins at up to 60,000 revolutions per minute (rpm) in the turbo pump.

Turbo pumps move gas by momentum transfer. The turbine blades are angled so that when they strike a gas molecule it is deflected downward. Each set of blades pushes the gas molecules further down toward the pump outlet. The foreline pump is connected by a hose to the outlet of the turbo pump. It removes the gas molecules that reach the outlet.

A controller regulates current to the pump and monitors pump motor speed and temperature. A cooling fan is located between the turbo pump and the front panel of the MSD. The fan draws air from outside the MSD and blows it over the pump.

The turbo pump automatically turns on when the MSD power is switched on. The system allows the analyzer to be turned on when the turbo pump is greater than 80% speed, but the pump normally operates at 100% speed. Turbo pump MSDs typically maintain an indicated pressure below  $8 \times 10^{-5}$  Torr for helium column flows up to 4 mL/minute for the performance turbo pump, and up to 2 mL/minute for the standard turbo pump. Pressure (vacuum) can only be measured if your MSD is equipped with the optional gauge controller.

The turbo pump spins up (starts) and spins down (stops) quickly. This simplifies pumpdown and venting. From initial power-on, the system can pump down to operating pressure in 5 to 10 minutes.

### See Also

- *To pump down the MSD in the Operating Manual*
- *To vent the MSD in the Operating Manual*
- *See “Turbo pump control” on page 205.*

## Calibration Valves and Vent Valve

### Calibration valves

A calibration valve is an electromechanical valve with a vial to hold the tuning compound. (See [Figure 33](#) on page 167.) When a calibration valve is opened, tuning compound in the vial diffuses into the ion source. EI MSDs have one calibration valve; CI MSDs have a second calibration valve for the CI tuning compound. The valves are controlled by the MSD Data Acquisition.

#### EI calibration valve

The EI calibration valve is held onto the top of the analyzer chamber by two screws. A small O-ring provides a face seal.

The DP has a calibration valve with less restriction than that in the turbo MSD; this allows the correct diffusion of calibrant for each vacuum system.

PFTBA is the most commonly used tuning compound for EI operation. PFTBA is required for automatic tuning of the MSD. Other compounds can be used for manual tuning.

#### CI calibration valve

The CI tuning compound is perfluoro-5,8-dimethyl-3,6,9-trioxidodecane (PFDTD). The CI calibration valve is part of the reagent gas flow control module. It is controlled by the Agilent MassHunter GC/MS Acquisition software. It opens automatically during CI autotune or manual tuning, allowing PFDTD to diffuse through the GC/MSD interface and into the ion source.

### Vent valve

The vent valve knob screws into a threaded port in the front of the calibration valve. (See [Figure 34](#) on page 168.) An O-ring is compressed between the knob and the valve to form a seal. The threaded end of the knob has an air passage inside it, allowing air to flow into the manifold when the knob is partially unscrewed. If you turn the knob too far, the O-ring can come out of its slot.

El calibration  
above analyzer window

Vent valve knob

El calibration vial

El calibration valve



CI calibration  
right side of MSD

CI calibration valve

CI calibration vial



Figure 33 Calibration valves

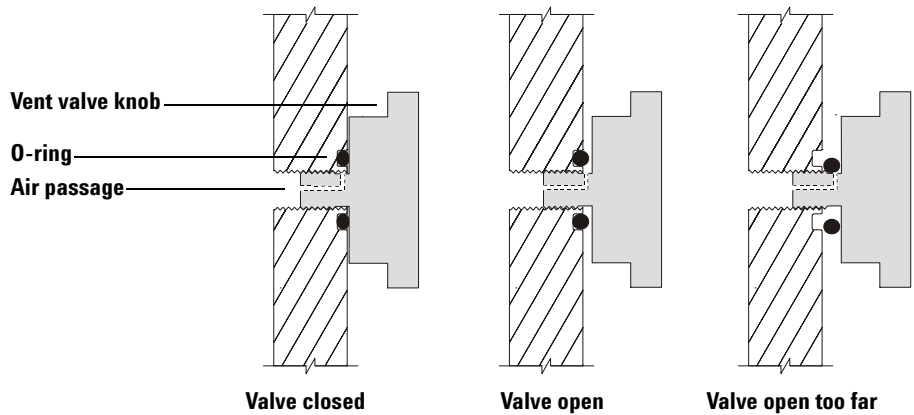

Figure 34 Vent valve

## Micro-Ion Vacuum Gauge

The G3397B Micro-Ion vacuum gauge is standard on CI MSDs and optional on EI MSDs. It consists of the sensing element (an ionization-type gauge) and the necessary electronics to support it. Both parts are mounted in a single package.

The ionization gauge creates a current when energized electrons collide with gas molecules. The electronics provide the voltages required, measure the current produced, and produce an output signal that is used by the MSD software.

The Micro-Ion vacuum gauge mounts on the end of the analyzer chamber and is open to it. This allows you to monitor chamber pressure in daily operation and in troubleshooting.

The gauge is calibrated for nitrogen ( $N_2$ ). The carrier gas is usually helium, which does not ionize as readily as nitrogen. Therefore, the *indicated* pressure for helium is approximately six times lower than the absolute pressure. For example, a reading of  $2.0 \times 10^{-5}$  Torr versus an absolute pressure of  $1.2 \times 10^{-4}$  Torr.

In a CI MSD, the indicated pressure reflects the contribution of both the carrier gas and the reagent gas. The distinction between indicated and absolute pressure is not important for normal operation of the MSD. Of greater concern are changes in pressure from hour to hour or day to day. These changes can indicate air leaks or other problems with the vacuum system. All the pressures listed in this manual are indicated pressures for helium carrier gas. The gauge controller setpoints are also indicated pressures.

## **6 Vacuum System**

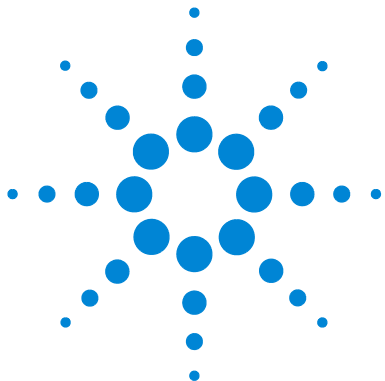

## 7 Analyzer

Overview	172
EI Source	174
EI HES Source	181
CI Source	184
Filaments	188
Other Source Elements	190
Quadrupole Mass Filter	192
Detector	195
Analyzer Heaters and Radiators	197



### Overview

The analyzer is the heart of the MSD. (See [Figure 35](#) on page 173.) It ionizes the sample, filters the ions, and detects them. The sample components exiting the GC column flow into the ion source. In the ion source, the sample molecules are ionized and fragmented. The resulting ions are repelled from the ion source into the Quad. The mass filter allows selected ions to pass through the filter and strike the detector. The detector generates a signal current proportional to the number of ions striking it.

The analyzer is attached to the vacuum side of the side plate. The side plate is hinged for easy access. The ion source and the mass filter are independently heated. Each is mounted inside a radiator for correct heat distribution.

Each of the parts of the analyzer is discussed in the following material.

#### **The analyzer has four basic components**

The analyzer consists of the following components: (See [Figure 35](#) on page 173.)

- Ion source
- Mass filter
- Detector
- Heaters and radiators



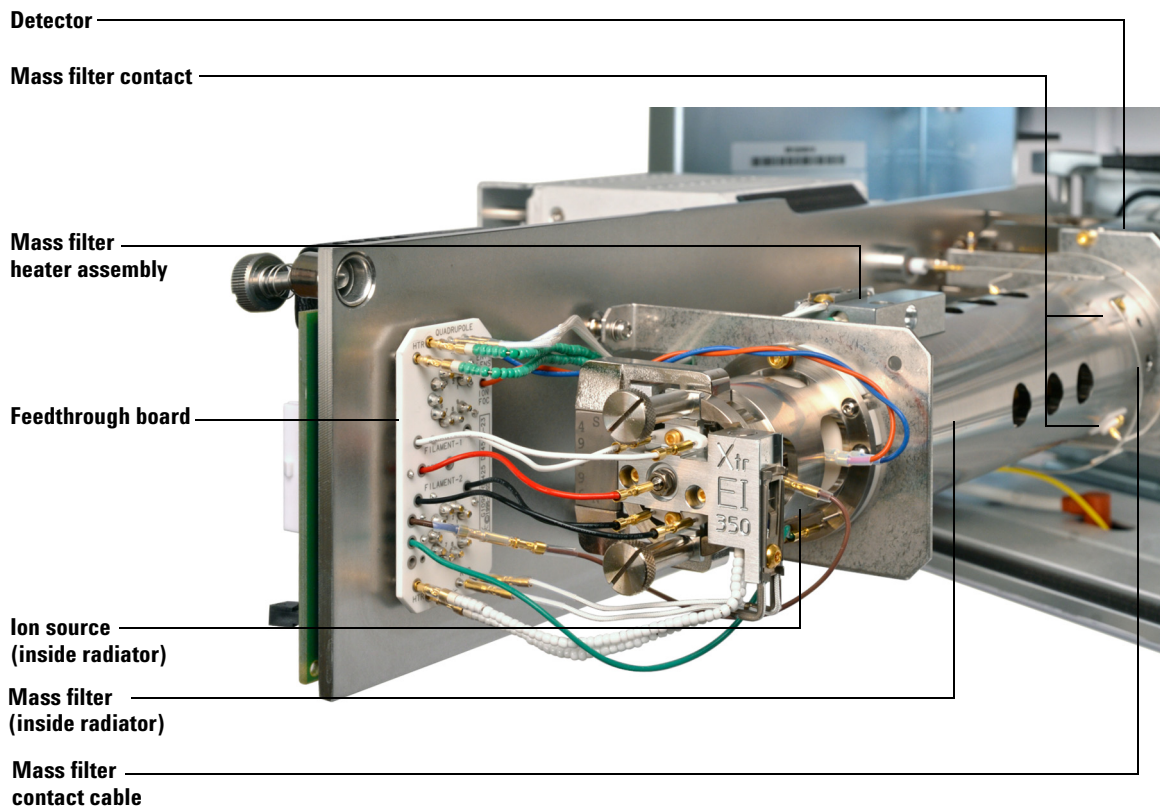

**Figure 35** The analyzer

### El Source

The EI source operates by electron ionization. (See [Figure 36](#) on page 175.) The sample enters the ion source from the GC/MSD interface. Electrons emitted by a filament enter the ionization chamber, guided by a magnetic field. The high-energy electrons interact with the sample molecules, ionizing and fragmenting them. The positive voltage on the repeller pushes the positive ions into the lens stack, where they pass through several electrostatic lenses. These lenses concentrate the ions into a tight beam, which is directed into the mass filter.

#### Ion source body

The ion source body is a cylinder. (See [Figure 36](#) on page 175 and [Figure 37](#) on page 176.) It holds the other parts of the ion source, including the lens stack. With the repeller, and in the SST/Inert ion source, the drawout plate, it forms the ionization chamber. The ionization chamber is the space where the ions are formed. Slots in the source body help the vacuum system to pump away carrier gas and unionized sample molecules or fragments.

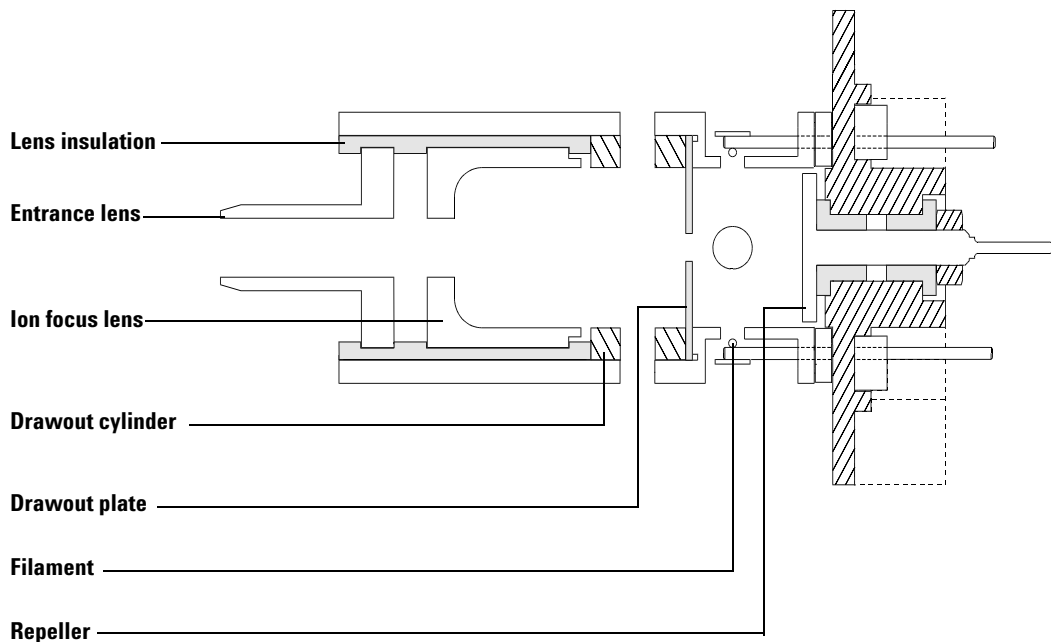

**Figure 36** SST/Inert ion source structure

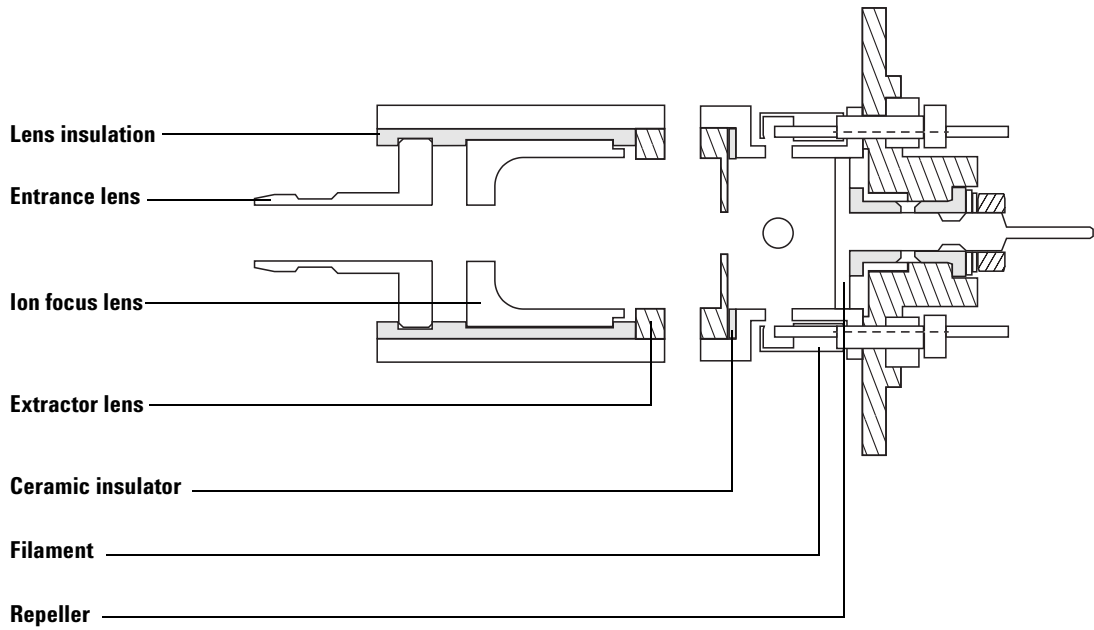
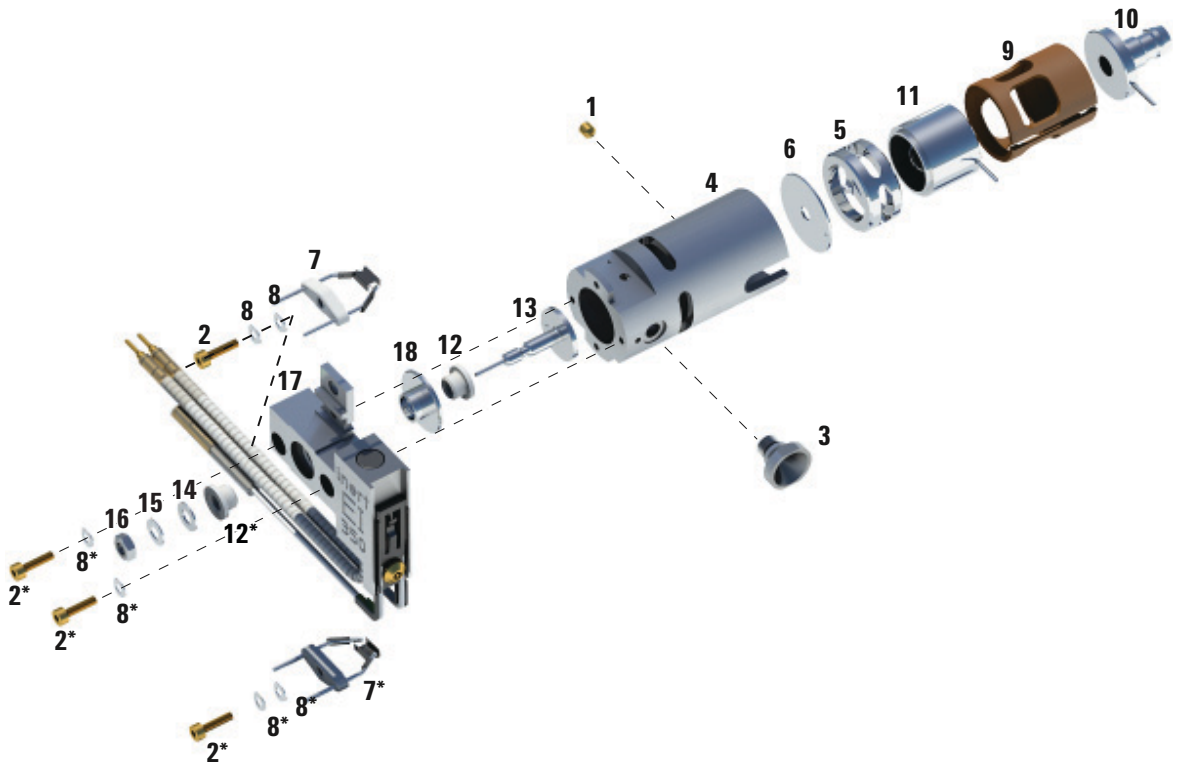

Figure 37 EI XTR source structure



**Figure 38** SST/Inert ion source

**Table 12** Parts list for the standard or inert EI source (Figure 38 on page 177)

Item number	Item description	Part number (SSL)	Part number (Inert)
1	Gold plated set screw	G1999-20022	G1999-20022
2	Gold plated screw	G3870-20021	G3870-20021
3	Interface socket	G1099-20136	G1099-20136
4	Source body	G1099-20130	G2589-20043
5	Drawout cylinder	G1072-20008	G1072-20008

## 7 Analyzer

**Table 12** Parts list for the standard or inert EI source (Figure 38 on page 177) (continued)

Item number	Item description	Part number (SSL)	Part number (Inert)
6	Drawout plate	05971-20134	G2589-20100
7	4-turn filament	G7005-60061	G7005-60061
8	Spring washer	3050-1374	3050-1374
8	Flat washer	3050-0982	3050-0982
9	Lens insulator	G3170-20530	G3170-20530
10	Entrance lens	G3170-20126	G3170-20126
11	Ion focus lens	05971-20143	05971-20143
12	Repeller insulator	G1099-20133	G1099-20133
13	Repeller	G3870-60172	G3870-60173
14	Flat washer	3050-0627	3050-0627
15	Belleville spring washer	3050-1301	3050-1301
16	Repeller nut	0535-0071	0535-0071
17	Source heater block assembly	G3870-60180	G3870-60179
18	Repeller block insert	G3870-20135	G3870-20135

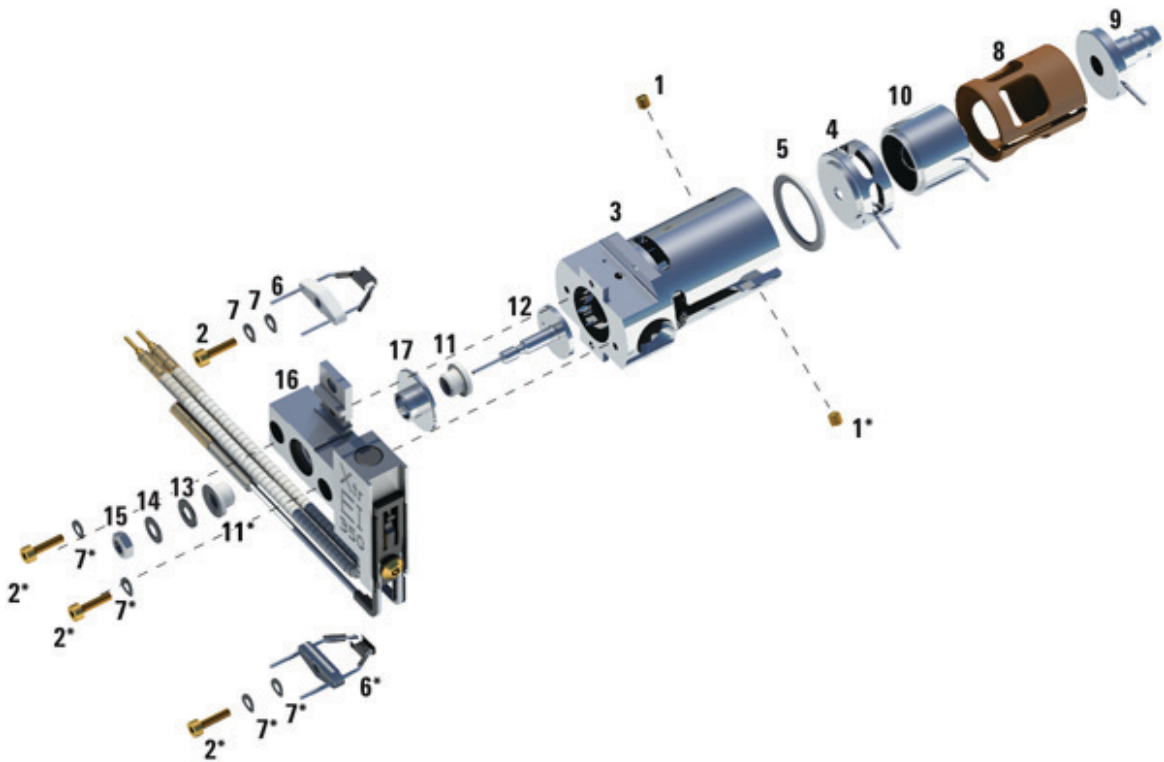

**Figure 39** EI XTR source

**Table 13** Parts list for EI XTR source (Figure 39)

Item	Description	Part number
1	Setscrews	G3870-20446
2	Screws	G3870-20021
3	Source body	G3870-20440
4	Extractor lens	G3870-20444
5	Extractor lens insulator	G3870-20445

**Table 13** Parts list for EI XTR source (Figure 39) (continued)

<b>Item</b>	<b>Description</b>	<b>Part number</b>
6	Filaments	G7005-60061
7	Spring washer	3050-1301
7	Flat washer	3050-0982
8	Lens insulator	G3870-20530
9	Entrance lens assembly, Extended	G7000-20026
10	Ion focus lens	05971-20143
11	Repeller insulator	G1099-20113
12	Repeller	G3870-60171
13	Flat washer	3050-0891
14	Belleville spring washer	3050-1301
15	Repeller nut	0535-0071
16	Source heater block assembly	G3870-60177
17	Repeller block insert	G3870-20135
Not shown	EI XTR source assembly	G7003-67720

The CI source is similar in design, but critical dimensions are different. Do not interchange parts.



## EI HES Source

The EI HES source operates by EI. The sample enters the ion source from the GC/MS interface. Electrons emitted by a filament enter the ionization chamber, guided by a magnetic field. The high-energy electrons interact with the sample molecules, ionizing and fragmenting them. The positive voltage on the repeller pushes the positive ions into the lens stack, where they pass through several electrostatic lenses. These lenses concentrate the ions into a tight beam, directed into the mass filter.

### Ion source body

The ion source body is a cylinder. It holds the other parts of the ion source, including the lens stack. The repeller, source mount, and filament block form the ionization chamber. The ionization chamber is the space where the ions are formed. Slots in the source body help the vacuum system to pump away carrier gas and un-ionized sample molecules or fragments.

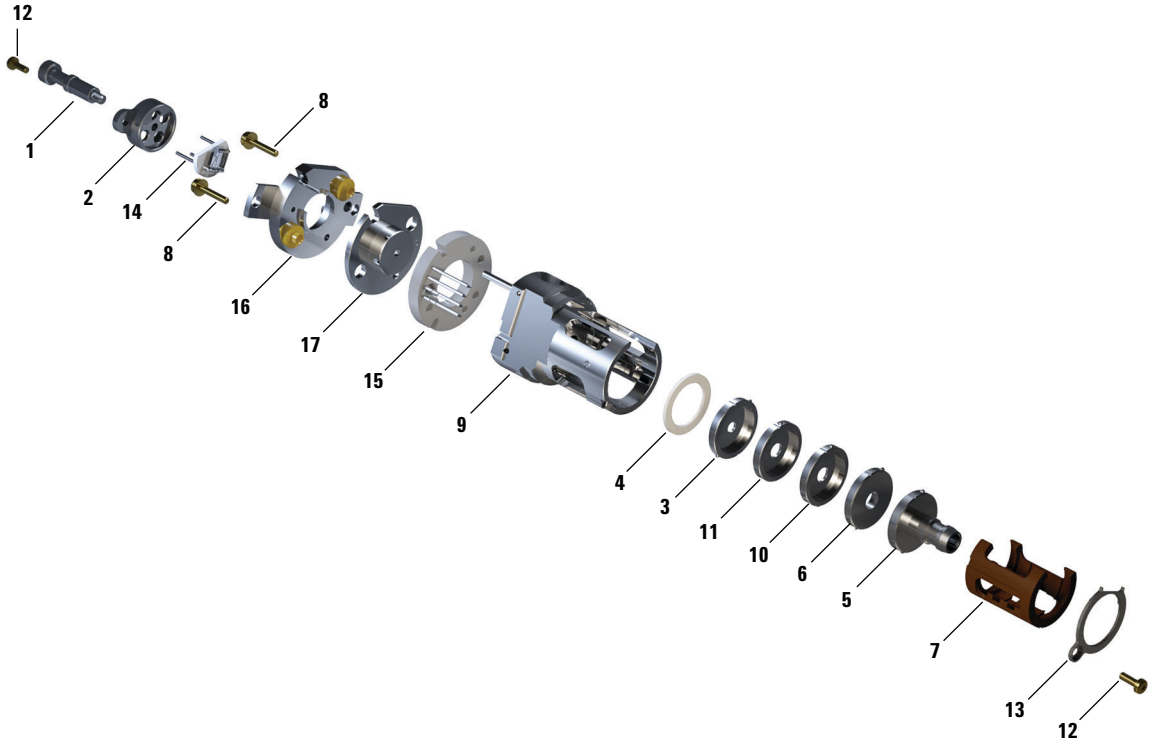

**Figure 40** EI HES source

**Table 14** Parts list for EI HES (Figure 40)

Item number	Item description	Part number
1	Source finger grip	G7002-20008
2	Filament block	G7002-20019
3	Extractor lens (5)*, with 3 mm opening	G7002-20061
4	Ceramic insulator for extractor	G7002-20064
5	Entrance lens assembly, Extended, HES (1)*	G7002-20165
6	Ion focus lens (2)*	G7002-20068

**Table 14** Parts list for EI HES (Figure 40) (continued)

Item number	Item description	Part number
7	Lens insulator/holder	G7002-20074
8	M2 x 0.4 screw x 12 mm long gold plated screw	G7002-20083
9	Source body	G7002-20084
10	Post extractor lens 2 (3)*	G7002-20090
11	Post extractor lens 1 (4)*	G7002-20104
12	M2 x 6 mm gold plated screw	G7002-20109
13	Locking ring lens insulator	G7002-20126
14	High efficiency dual filament	G7002-60001
15	Ring heater/sensor assembly	G7002-60043
16	Source mount 1.5 mm	G7002-60053
17	Repeller assembly	G7002-60057
Not shown	HES assembly	G7004-67055

## CI Source

The CI source is similar in shape to the traditional EI source, but only has one part in common with the EI source – the entrance lens. The single CI filament has a straight wire and a reflector. A “dummy” filament provides connections for the other wires.

The holes in the ion source (electron-entrance and ion-exit) are very small (0.5 mm), making it possible to pressurize the ionization chamber. Both the source body and the plate are at repeller potential, electrically isolated from the radiator and the interface tip. The seal for the interface tip ensures a leak-tight seal and electrical isolation between the CI interface and ion source. (See [Figure 42](#) on page 185.)

### Ion source body

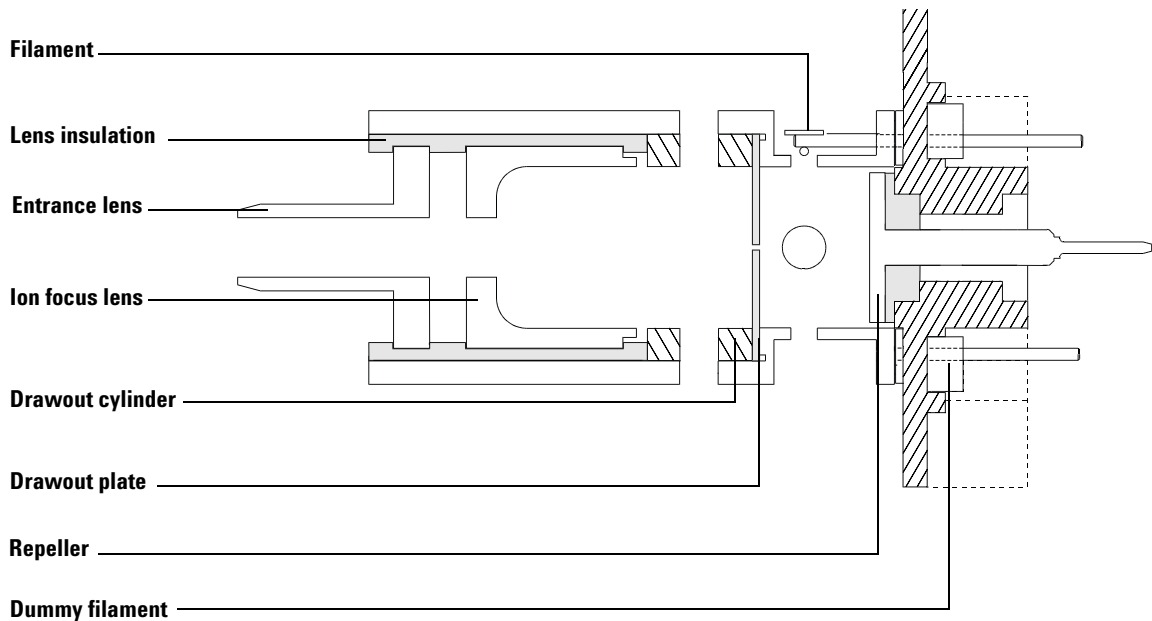

**Figure 41** CI source structure



**Figure 42** Interface tip seal

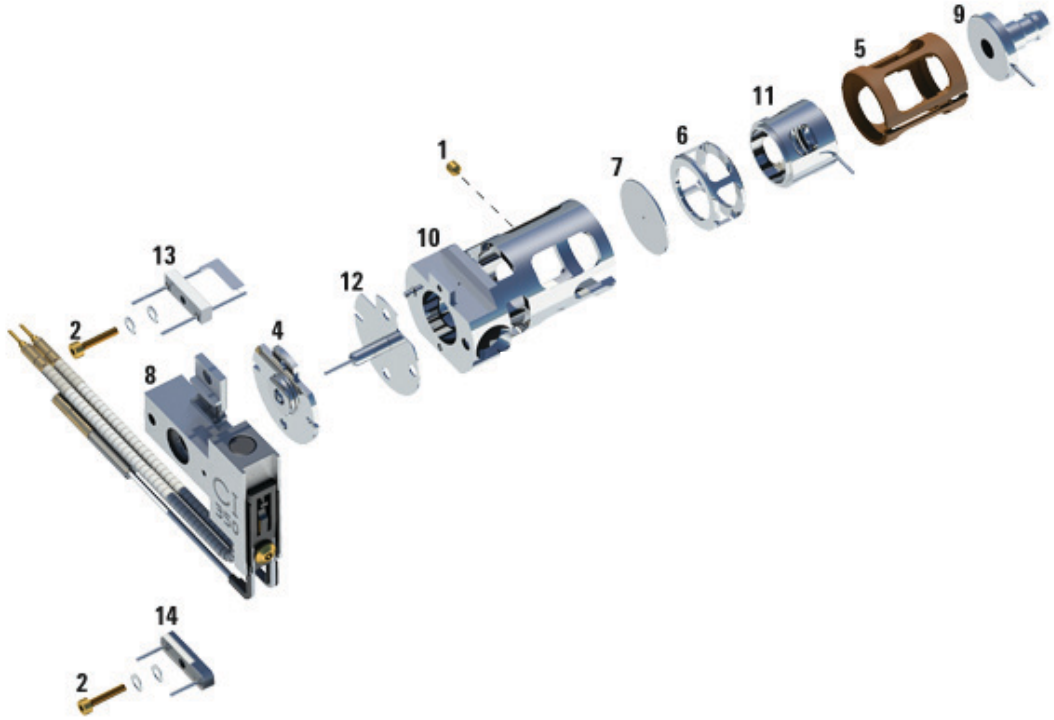

Figure 43 CI source

Table 15 Parts list for CI source (Figure 43)

Item	Description	Part number
1	Set screw	G1999-20022
2	Filament screw	G1999-20021
3	CI repeller insulator	G1999-20433
4	CI lens insulator	G3170-20540
5	CI drawout cylinder	G1999-20444
6	CI drawout plate	G1999-20446

**Table 15** Parts list for CI source (Figure 43) (continued)

<b>Item</b>	<b>Description</b>	<b>Part number</b>
7	CI source heater block assembly	G3870-60415
8	Entrance lens	G7000-20026
9	CI source body	G3170-20430
10	Ion focus lens	G1999-20443
11	CI repeller	G7077-20432
12	CI filament- 2PK	G7005-60072
13	Dummy filament	G1999-60454
14	Washer spring curved 2.2 mm-ID 4.5 mm-OD 0 Qty. 2	3050-1374
15	Flat washer	3050-9082
Not shown	Package, GC source Clamshell	G7002-80008
Not shown	Bracket, GC source, Clamshell	G7002-00008
Not shown	350 CI source assembly	G7002-67404
Not shown	350 CI source assembly (without tip seal)	G7077-67404

## Filaments

Two filaments are located within the ion source mount of the EI HES source, or are located on opposite sides of the outside of the SS, Inert, and XTR ion sources. The **active** filament carries an adjustable AC emission current. The emission current heats the filament causing it to emit electrons which ionize the sample molecules. In addition, **both** filaments have an adjustable DC bias voltage. The bias voltage determines the energy on the electrons, usually  $-70$  eV for the SS, inert, and inert+ ion sources, or  $-120$  eV for the EI HES source.

The CI source has only one filament of a different design from the EI filaments. A dummy filament provides connections for the Filament 2 wires.

The filament is shut off automatically if there is a general instrument shutdown. Three parameters affect the filaments: filament selection (Filament), filament emission (Emission) current, and electron energy (EIEnrgy).

### Filament selection

The filament selection parameter (Filament) selects which filament in the ion source is active. In the CI source, it is always Filament 1.

Sometimes, one EI filament will give better performance than the other does. To select the better of the two filaments, run two autotunes, one with each filament. Use the filament that gives the best results.

### Emission current

The filament emission current (Emission) is variable between 0 and  $-315$   $\mu$ A, but should be set to the software default for normal operation.

### Electron energy

The electron energy (EIEnrgy) is the amount of energy on the ionizing electrons. It is determined by the bias voltage;  $-70$  VDC bias on the filament causes emitted electrons to possess  $-70$  eV (eVs). This value is adjustable from  $-5$  to  $-241$  VDC, but for normal operation with an HES source, set this parameter to 120. For normal operation with a SS, inert, or XTR source, set this parameter to 70.



## Filament care

Similar to the filaments in incandescent light bulbs, the ion source filaments will eventually burn out. Certain practices reduce the chance of early failure:

- If you have an optional G3397B Micro-Ion vacuum gauge, use it to verify that the system has an adequate vacuum before turning on the analyzer, especially after any maintenance was performed.
- If you are controlling your MSD from the **Manual Tune** screen, always select **MSOff** before changing any of the filament parameters.
- When setting up data acquisition parameters, set the solvent delay so that the analyzer will *not* turn on while the solvent peak is eluting.
- When the software prompts **Override solvent delay?** at the beginning of a run, *always* select **NO**.
- Higher emission current reduces filament life.
- Higher electron energy reduces filament life.
- Leaving the filament on for short times ( $\leq 1$  minute) during data acquisition reduces filament life.

## Other Source Elements

### Magnet

The field created by the magnet directs the electrons emitted by the filament into and across the ionization chamber. The HES source magnet assembly is a permanent magnet with a charge of 650 gauss in the center of the field. The CI, EI SS, EI inert, and EI XTR source magnet assembly is a permanent magnet with a charge of 350 gauss in the center of the field.

### Repeller

The repeller forms one wall of the ionization chamber. A positive charge on the repeller pushes positively-charged ions out of the source through a series of lenses. The repeller voltage is also known as the ion energy, although the ions only receive about 20% of the repeller energy. The repeller voltage can be varied from 0 to +42.8 VDC. Some tune programs use a fixed repeller voltage. Others ramp the repeller voltage to find the optimum setting.

- Setting repeller voltage too low results in poor sensitivity and poor high mass response.
- Setting repeller voltage too high results in precursors (poor mass filtering) and poor low mass resolution.

### Drawout plate and cylinder

The drawout plate forms another wall of the ionization chamber. The ion beam passes through the hole in the drawout plate and into the drawout cylinder. The drawout cylinder is slotted. The slots correspond to slots in the source body. These slots allow carrier gas and unionized sample molecules or fragments to be pulled away by the vacuum system. The drawout plate and drawout cylinder are both at ground potential. These are used in the standard, inert, and CI sources only.

### Extractor lens

A voltage is applied to the extractor lens to increase ion focusing through the source.

## Post extractor lens 1 and 2

The post extractor lenses are part of the lens stack in the EI HES source only. A voltage is applied to the two lenses to increase ion focusing through the source.

## Ion focus

The voltage on the ion focus lens can be varied from 0 to -127 VDC. A typical voltage is between -70 and -90 VDC. In general:

- Increasing the ion focus voltage improves sensitivity at lower masses.
- Decreasing the ion focus voltage improves sensitivity at higher masses.
- Incorrect ion focus adjustment results in poor high mass response.

## Entrance lens

The entrance lens is at the entrance to the Quad. This lens minimizes the fringing fields of the quadrupole which discriminate against high-mass ions.

### Entrance lens offset

The entrance lens offset (EntOff) controls the fixed voltage applied to the entrance lens. It can be varied from 0 to -64 VDC (-20 V is typical). Increasing the entrance lens offset generally increases the abundance of ions at low masses without substantially decreasing the abundance of high mass ions.

### Entrance lens gain

Entrance lens gain (EntLens) controls the variable voltage applied to the entrance lens. It determines how many volts are applied for each  $m/z$ . It can be varied from 0 to -128 mV/( $m/z$ ). A typical range is 0 to -40 mV/amu.

## Quadrupole Mass Filter

The mass filter separates ions according to their mass-to-charge ratio ( $m/z$ ). At a given time, only ions of a selected  $m/z$  can pass through the filter to the detector. The mass filter in the MSD is a quadrupole. (See [Figure 44](#) on page 193.)

The quadrupole is a fused-silica (quartz) tube coated with a thin layer of gold. The four hyperbolic surfaces create the complex electric fields necessary for mass selection. Opposing segments are connected; adjacent segments are electrically isolated. One pair has positive voltages applied, the other has negative voltages applied.

A combined DC and RF signal is applied to the two pairs of segments. The magnitude of the RF voltage determines the  $m/z$  of the ions that pass through the mass filter and reach the detector. The ratio of DC-to-RF determines the resolution (widths of the mass peaks). There are several parameters that control the DC and RF voltages. All these parameters are set by Autotune, but can be manually adjusted in the **Edit Tune Parameters** dialog. When manually adjusting parameters, the acceptable range is shown when the parameter is selected (MassHunter), or when an unacceptable value is entered (OpenLAB).

- AMU gain (AmuGain)
- AMU offset (AmuOffs)
- 219 width (Wid219)
- DC polarity (DC Pol)
- Mass (axis) gain (MassGain)
- Mass (axis) offset (MassOffs)
- MS quad temp

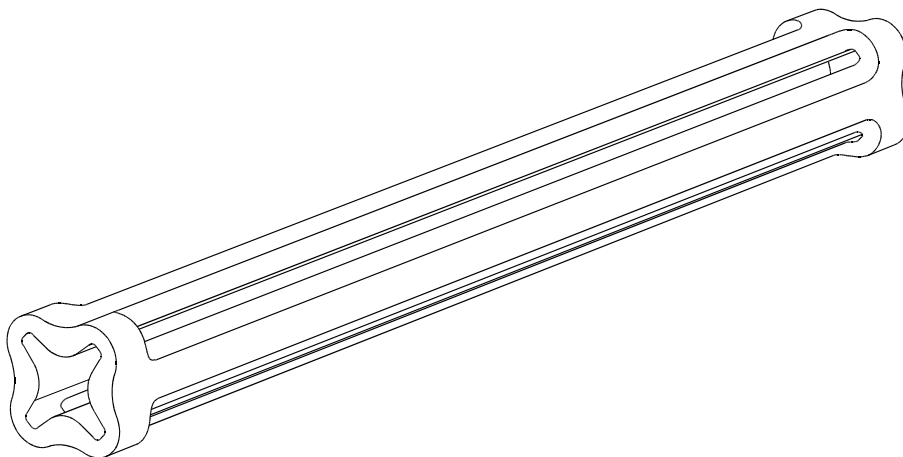

**Figure 44** Quad

## AMU gain

AMU gain (AmuGain) affects the ratio of DC voltage to RF frequency on the mass filter. This controls the widths of the mass peaks.

- Higher gain yields narrower peaks.
- AMU gain affects peaks at high masses more than peaks at low masses.

## AMU offset

AMU offset (AmuOffs) also affects the ratio of DC voltage to RF frequency on the mass filter.

- Higher offset yields narrower peaks.
- AMU offset generally affects peak widths equally at all masses.

## 219 width

$m/z$  219 is a prominent ion near the middle of the mass range of PFTBA. The width parameter (Wid219) makes small corrections to the  $m/z$  219 peak width. Amu gain and amu offset must be readjusted after the 219 width is changed. If you are tuning with a compound other than PFTBA, there may not be an ion at  $m/z$  219. In that case, set the 219 width to the last value found for it by Autotune, or set it to 0.

### DC polarity

The DC polarity (DC Pol) parameter selects the orientation of the DC applied to the Quad. The DC Pol that works best for your MSD is determined at the factory. It is listed on the final test sheet accompanying your MSD. It is also listed on a label on the cover over the RF coils. This cover can be viewed by removing the upper MSD cover.

#### CAUTION

Using the nonpreferred DC polarity may result in very poor performance. Always use the factory-specified polarity.

---

### Mass (axis) gain

Mass gain (MassGain) controls the mass assignment, that is, assignment of a particular peak to the correct  $m/z$  value.

- A higher gain yields higher mass assignment.
- Mass gain affects peaks at high masses more than peaks at low masses.

### Mass (axis) offset

Mass offset (MassOffs) also controls the mass assignment.

- A higher offset yields higher mass assignment.
- Mass offset generally affects peaks equally at all masses.

### Quadrupole maintenance

The mass filter requires no periodic maintenance. It should not be removed from the radiator. If **absolutely** necessary (that is, if the only alternative is replacement), the quadrupole can be cleaned. Cleaning **must** be performed by Agilent Technologies service personnel.

#### CAUTION

Never put the quadrupole in an ultrasonic cleaner.

Never change the physical orientation of the Quad.

The fused-quartz quadrupole is fragile and will break if dropped or handled roughly.

The material in the cusps of the quadrupole is very hygroscopic. If exposed to water, the quadrupole must be dried very slowly to prevent damage.

---

## Detector

The detector in the MSD analyzer is a high energy conversion dynode (HED) coupled to an EM. (See [Figure 45](#) on page 196.) The detector is located at the exit end of the Quad. It receives the ions that have passed through the mass filter. The detector generates an electronic signal proportional to the number of ions striking it. The detector has three main components: the detector ion focus, the HED, and the EM horn.

### Detector ion focus

The detector ion focus directs the ion beam into the HED, which is located off axis. The voltage on the detector focus lens is fixed at  $-600$  V.

### High energy dynode

The HED operates at  $-10,000$  V for EI and PCI, and  $+10,000$  V for NCI. It is located off-axis from the center of the Quad to minimize signals due to photons, hot neutrals, and electrons coming from the ion source. When the ion beam hits the HED, electrons are emitted. These electrons are attracted to the more positive EM horn. Do not touch the insulator.

### EM horn

The EM horn carries a voltage of up to  $-3,000$  V at its opening and  $0$  V at the other end. The electrons emitted by the HED strike the EM horn and cascade through the horn, liberating more electrons as they go. At the far end of the horn, the current generated by the electrons is carried through a shielded cable outside the analyzer to the signal amplifier board.

The voltage applied to the EM horn determines the gain. The voltage is adjustable from  $0$  to  $-3,000$  VDC. Use the EM voltage found in autotune as a baseline for the EM voltage setting.

- To increase signal gain, increase the EM voltage.
- For concentrated samples where less signal gain is needed, decrease the EM voltage.

As the EM horn ages, the voltage (EMVolts) required increases over time. If the EM voltage must always be set at or near  $-3,000$  VDC to complete Autotune, with no other probable cause, it may need to be replaced. Check your tune

charts for gradual degradation, which indicates wearing out. Select the **Tune Plot** icon from the **Program** menu of your desktop to see the tune plots. Sudden changes usually indicate a different type of problem.

### See Also

- *Troubleshooting* in the online help for more information about symptoms that may indicate EM problems.

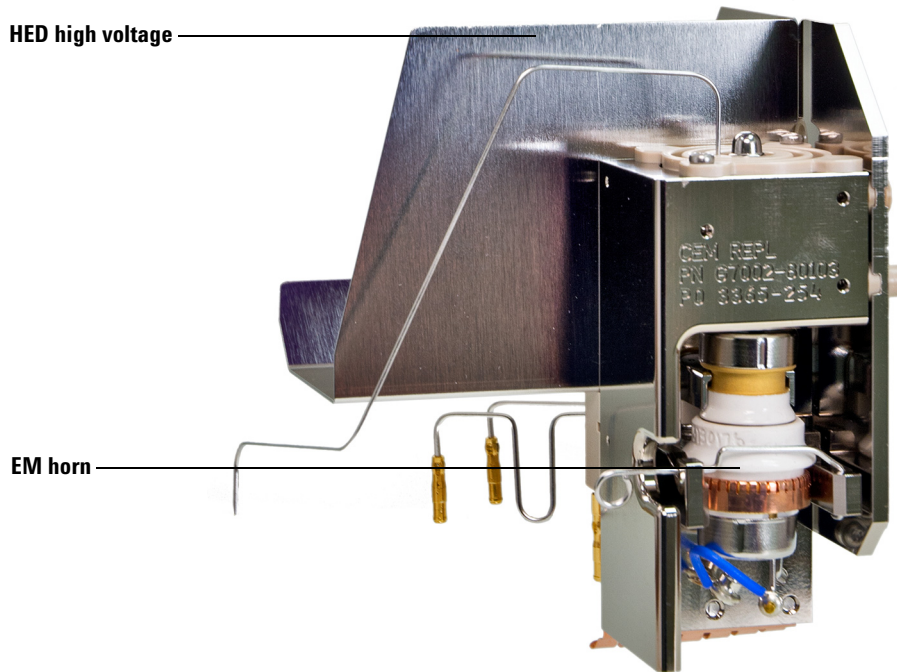

**Figure 45** The detector



## Analyzer Heaters and Radiators

The ion source and mass filter are housed in cylindrical aluminum tubes called radiators. (See [Figure 46](#) on page 198.) The radiators control the distribution of heat in the analyzer. They also provide electrical shielding for analyzer components. The source heater and temperature sensor are mounted in the source heater block. The mass filter (quad) heater and temperature sensor are mounted on the mass filter radiator. Analyzer temperatures can be set and monitored from the Agilent MassHunter GC/MS Acquisition software.

In selecting the temperatures to use, consider the following:

- Higher temperatures help keep the analyzer clean longer.
- Higher ion source temperatures result in more fragmentation and, therefore, lower high-mass sensitivity.

After pumpdown, it takes at least 2 hours for the analyzer to reach thermal equilibrium. Data acquired sooner may not be reproducible.

Recommended settings (for EI operation):

- Ion source 230 °C
- Quadrupole 150 °C

### CAUTION

Do not exceed 200 °C on the quadrupole, or 350 °C on the ion source.

---

The GC/MSD interface, ion source, and mass filter (quad) heated zones interact. The analyzer heaters may not be able to accurately control temperatures if the setpoint for one zone is much lower than that of an adjacent zone.

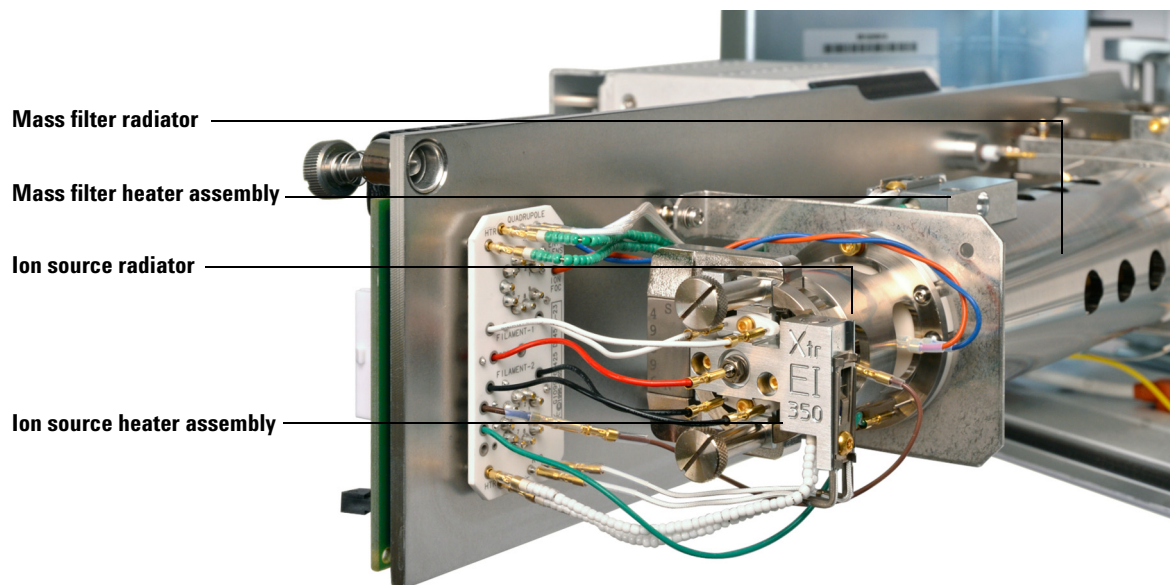

**Figure 46** Heaters and radiators

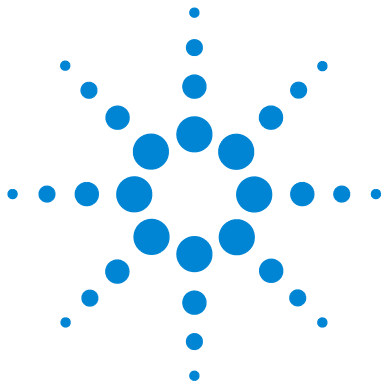

## 8 Electronics

Local User Interface, Power Switch, and Front Panel LED	200
Side Board	202
Electronics Module	203
LAN/MS Control Card	207
Power Supplies	208
Back Panel and Connectors	209
Interfacing to External Devices	212

Most of this material is not essential for day-to-day operation of the MSD. It may be of interest to persons responsible for servicing the MSD.

### **WARNING**

**Dangerous voltages are present under the safety covers. Do not remove safety covers. Refer servicing to your Agilent Technologies service representative.**

---



## Local User Interface, Power Switch, and Front Panel LED

### Local user interface

You can view MSD system status, perform instrument configuration, and some operational functions from the control panel on an LVDS connected 7890B GC.

Functions available through the 7890B Series GC control panel include:

- Configure network settings of the MSD
- Change the MSD analyzer temperatures
- View analyzer vacuum or turbo pump speed
- View foreline pump vacuum
- Vent or pumpdown the MSD
- View the FW version and serial number of the MSD
- Enable LVDS on the MSD
- Reboot the MSD
- Enable BOOTP on the MSD

### Power switch

The power switch is part of the electronics module, and is located on the lower left of the front of the MSD. It is used to turn the MSD and foreline pump on and off.

#### CAUTION

Do not switch the MSD off unless it has completed the vent program. Incorrect shutdown can seriously damage the MSD.

---

### Front panel instrument status LED

Through the front panel instrument status LED, the operator can view the current status of the instrument using color codes and LED on/off timing. (See [Table 16](#) on page 201.)

**Table 16** Front panel Instrument Status LED codes

<b>Instrument status</b>	<b>LED code</b>
Ready	Solid green
Acquiring data	Blinking green (<2 sec)
Not ready	Solid yellow
JetClean <b>Acquire &amp; Clean</b> operation	Blinking magenta
JetClean <b>Clean Only</b> operation	Solid magenta
Ready and not connected to DS	Solid blue
Start up (prior to FW load)	Blinking red (<2 sec)
Fault	Solid red

## Side Board

The side board is mounted on the side plate. It performs these functions:

- Provides the 1 MHz reference clock for the RF amplifier.
- Generates the RF component of the voltage applied to the Quad according to a signal from the main board. The amplitude of this voltage is proportional to the mass selected.
- Generates the DC component of the voltage applied to the Quad. The magnitude of this voltage is proportional to the RF voltage.
- Passes voltages generated on the main board and the detector focus voltage from the HED power supply to elements in the ion source and the detector.
- Generates and adjusts filament emission current and electron energy as controlled by the main board.
- Switches the filament power from one filament to the other.
- Monitors for RF faults and shuts down the analyzer if one is detected.

## Electronics Module

Most of the electronics in the MSD are contained in the electronics module. The whole electronics module can be replaced, if necessary, by your Agilent Technologies service representative.

The electronics module contains:

- Main board
- Signal amplifier board
- LAN/MS control card
- AC board (power distribution/vacuum control board)
- Low voltage (AC-DC) power supply
- High voltage (HED) power supply
- Toroid transformer assembly
- Lens driver board

### Main board

The main board is mounted on the outer side of the electronics module. The main board performs these functions:

- Receives and decodes digital instructions from the LAN/MS control card.
- Sends digital information to the LAN/MS control card.
- Generates voltages for the ion source lenses.
- Generates control signals for filament selection, filament emission current, and electron energy. Generates control signals for quadrupole RF drive, quad frequency adjustment, DC polarity selection, and all detector voltages.
- Performs analog-to-digital conversion for the Direct signal, ion source and mass filter temperature signals, and foreline pressure or turbo pump speed signal.
- Monitors the signals from the vacuum system and fans and the filament status, HV fault and RF fault signals from the side board. Activates the shutdown line when the analyzer electronics must be disabled.
- Generates the control signals (on and off) used by the AC board for the high vacuum pump and calibration valve.

- Generates  $\pm 280$  VDC (nominal) power for main board lens amplifiers and side board DC amplifiers.
- Supplies and controls the power for the ion source and quadrupole (mass filter) heaters.
- Provides 24 VDC power for the cooling fans.

### Signal amplifier board

The signal amplifier board amplifies the output of the detector. It produces an output voltage of 0 to 10 V DC, proportional to the logarithm of the input current of 3 picoamps to 50 microamps.

An analog-to-digital converter converts the amplifier output voltage to digital information. The LAN/MSD control card converts the data into abundance counts proportional to the detector signal current.

### Lens driver board

The lens driver board provides the lens voltages for the extractor, post extractor 1, and post extractor 2 lenses. This board is only present on the G7079 model.

### AC board

The AC board is mounted on the opposite side of the electronics panel from the LAN/MSD control card. The AC board is also sometimes called the power distribution/vacuum control board. It performs these functions:

- Provides input voltage transparency for the MSD.
- Distributes AC line power to the AC/DC power supply, the foreline pump, and the turbo pump controller.
- Turns the calibration valve on or off as directed by the main board.
- Provides the voltage for the calibration valve.
- Provides a logic interface to turbo controller.
- Controls the DP:
  - Controls the foreline gauge.
  - Turns on the DP once the foreline pressure is low enough, as directed by the main board.
  - Regulates the AC power to the DP heater.



- Turns off the DP if the foreline pressure is too high or if the DP is too hot.
- Passes the foreline pressure signal from the foreline gauge or turbo pump speed and other vacuum status information to the main board.
- Turns off the foreline pump in case of a problem with pumpdown.

### DP control

The power regulator ensures that the DP heater receives constant power, even if there are fluctuations in the AC line voltage. It measures the voltage across the heater and the current through it, multiplies them together, and compares the result with a standard value. Any discrepancy is applied as an error signal to adjust the power.

If the power distribution board senses a malfunction in the DP power regulator, it shuts off power to the DP. (See [Figure 47](#).)

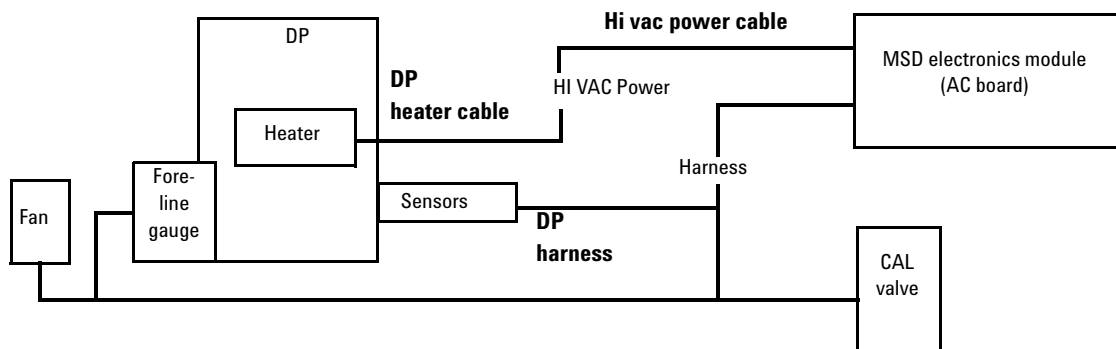

**Figure 47** DP control

### Turbo pump control

Your MSD is equipped with a turbo pump with an integrated controller.

The AC board sends control signals to, and receives turbo pump status information from, the turbo pump controller. The turbo pump controller provides power to the turbo pump and regulates pump speed. If the pump fails

to reach 80% speed within 7 minutes after beginning pumpdown or if the speed drops below 50% during operation, the controller shuts off the turbo pump and the AC board shuts off the foreline pump.

### **Pumpdown failure shutdown**

The AC board will shut down both the high vacuum and the foreline pump if the system fails to pump down correctly. Other conditions that trigger shutdown are turbo pump speed below 80% after 7 minutes, or foreline pressure above 300 mTorr after 7 minutes.

This is usually because of a *large* air leak: either the sideplate has not sealed correctly, or the vent valve is still open. This feature helps prevent the foreline pump from sucking air through the system, which can damage the analyzer and pump.

To correct the problem, power cycle the MSD and troubleshoot. You have 7 minutes to find and correct the air leak before the system shuts down again. Press on the side plate when turning on the MSD power to ensure a good seal.

## LAN/MS Control Card

The LAN/MS control card is located to the left of the main board on the electronics panel. The LAN/MS control card has two main functions:

- Providing a communication interface between the MSD and the DS
- Providing real-time control of the MSD, freeing the DS for other tasks

Functional areas of the LAN/MS control card include:

- Instrument controller
- Data processor
- Main processor
- Serial communication processor
- Network communication controller
- Remote start processor
- Random access memory (RAM)
- Status LEDs
- LCP FW
- Mini display module

LEDs on the LAN/MS control card are visible on the rear panel. The upper two LEDs indicate network communication.

The two bottom LEDs are the power (On, digital 5 V) and the heartbeat indicator. The flashing heartbeat LED indicates that the operating system of the MSD is functioning. In case of catastrophic loss of flash memory, the heartbeat flashes in an SOS (•••- - - •••) pattern.

## Power Supplies

### Low voltage (AC-DC) power supply

The low voltage power supply is mounted next to the toroid transformer in the electronics module. A universal input power supply, it converts AC line voltage into the DC voltages used by the rest of the electronics. The power supply generates the following DC voltages:

- +24 V (nominal)
- +15 V (nominal)
- -15 V (nominal)
- +5 V (nominal)

### High voltage (HED) power supply

The high voltage power supply provides the -10,000 V DC for the high energy dynode (HED) in the detector for the EI MSD. The EI/PCI/NCI MSD requires a bipolar power supply that can also provide +10,000 V for NCI operation. The HED power supply also provides 600 VDC for the detector focus lens. Due to the high impedance of this circuit, measuring the detector focus voltage with a handheld voltmeter will give a typical reading of 90 to 100 V where the polarity matches that of the HED voltage.

### Toroid transformer

The toroid transformer is mounted next to the AC board. It provides 24 VAC for the mass filter and source heater circuits. The input wires take 120 VAC or 200 to 260 VAC from the AC board. The AC board samples the line voltage and uses a relay to appropriately strap the toroid primary. The output wires connect to the main board.

## Back Panel and Connectors

The back panel contains several connectors, the primary fuses, and several status LEDs. (See [Figure 48](#) on page 211.) Most of these components are part of the AC board or the LAN/MS control card, and extend through the back panel.

### HI-VAC SIGNAL

The high vacuum signal connector is on the AC board. (See [“Turbo pump control”](#) on page 205 and [“DP control”](#) on page 205.)

### HI-VAC POWER

The high vacuum power connector carries power for the DP heater or the turbo controller from the AC board.

### Primary fuses

The primary fuses limit current into the MSD in case of a short circuit in the foreline pump. The primary fuses are on the AC board.

### Power cord receptacle

The AC power cord brings in all electrical power for the MSD. The power cord can be detached from the MSD.

### FORELINE PUMP

The foreline pump power cord receptacle provides AC power for the foreline pump. If the power switch is off, no power is supplied to the foreline pump.

### REMOTE

The remote start connector is the external connector for the remote start circuitry on the LAN/MS control card. It receives remote start signals from the GC.

### **High vacuum gauge connector**

This powers the high vacuum gauge and connects its signal to the controlling electronics.

### **SERIAL A**

This RS-232 connector is not currently used.

### **CI COMM**

This RS-232 connector goes to the CI flow module if it is installed on the MSD. It handles data communication between the GC and the MSD.

### **LAN**

The LAN cable from the DS is connected to this LAN connector. This cable carries all data communication between the PC and the MSD.

### **LAN/MSD control card LEDs**

The two upper LEDs indicate network communication. The two bottom LEDs are the power and the heartbeat indicator.

### **GC COMM**

This RS-232 cable connector is used for LVDS communication with a supported GC.

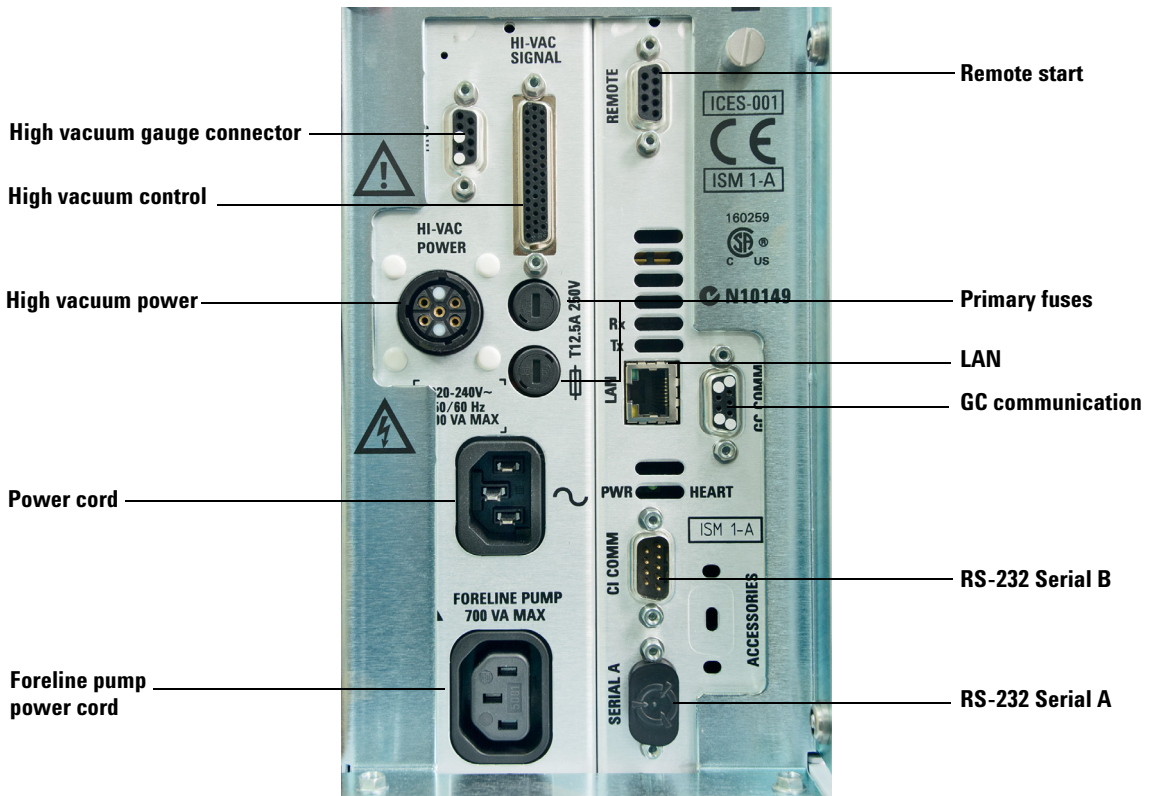

Figure 48 Back panel connections

## Interfacing to External Devices

### Remote control processor

The remote control processor on the LAN/MS control card synchronizes start-run signals with GCs and other devices. The functions of the remote control processor are extended to the remote start (Remote) connector on the back panel of the MSD. (See [Figure 49](#).) The remote start cable connects the GC and the MSD.

### Remote start signals

It is often necessary to communicate with external devices (for example, a purge-and-trap) during a run. Typically, these communications are requests to send a system-ready signal. They also include:

- Receive a start run signal from an external device
- Program the timing of events during a run

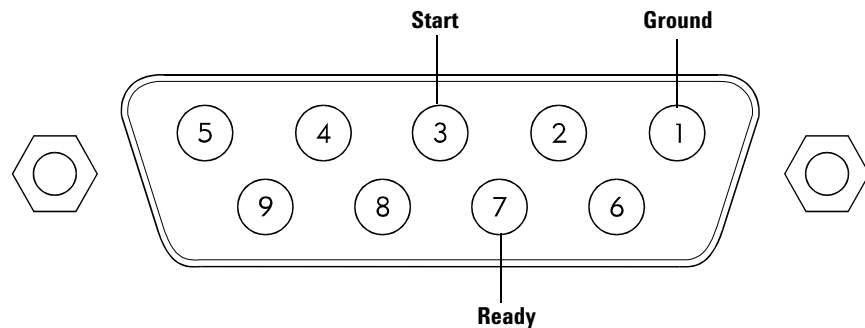

**Figure 49** Remote start connector

### System ready

When interfacing to an external device, it is often desirable to send a system-ready signal to the device. In the case of a multisample Tekmar purge-and-trap, each sample is purged onto a trap where it waits for a ready



signal. On receipt of the ready signal, the desorbption cycle begins. When a specific temperature is reached, the purge-and-trap closes a contact to indicate the run has started.

The ready pin on the remote start connector on the GC is held low at all times except when the GC, MSD, and DS are all ready. On system ready, a logic high of 5 VDC is present between that pin and any ground. This same high can be detected between the ready and ground pins on the remote start connector on the MSD.

### **Start run input**

The best way to generate a start run signal is to use the remote start connector on the GC. Since remote start cables are made for most common devices, this is often the simplest way. A general-purpose remote start cable (05890-61080), that terminates in spade lugs, is also available. Ensure that the system is actually ready before the start run signal is sent.

If necessary, the remote start connector on the back of the MSD can be used to send the start run signal. A contact closure between the start and ground pins will start the run, if the system is ready.



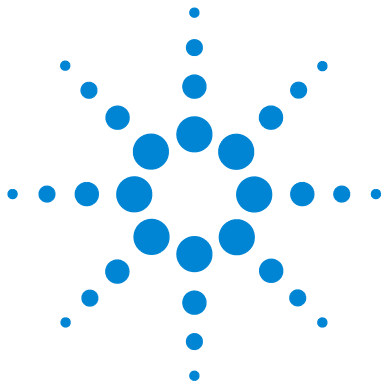

## 9 Parts

To Order Parts	216
Electronics	217
Vacuum System	218
Analyzer	226
Consumables and Maintenance Supplies	240

This chapter lists parts that can be ordered for use in maintaining your 5977B Series MSD. It includes most of the parts or assemblies in the MSDs. This chapter is organized so that related parts are grouped together.

Some of the parts listed are not user-replaceable. They are listed here for use by Agilent Technologies service representatives.



## To Order Parts

To order parts for your MSD, contact your local Agilent Technologies office. Supply them with the following information:

Model and serial number of your MSD, located on a label on the lower left side near the front of the instrument.

- Part number(s) of the part(s) needed
- Quantity of each part needed

### Some parts are available as rebuilt assemblies

Rebuilt assemblies pass all the same tests and meet all the same specifications as new parts. Rebuilt assemblies can be identified by their part numbers. The first two digits of the second part of the part number are 69 or 89 (such as xxxxx-69xxx or xxxxx-89xxx). Rebuilt assemblies are available on an exchange-only basis. When you return the original part to Agilent Technologies (after you receive the rebuilt assembly), you will receive a credit.

### If you cannot find a part you need

If you need a part that is not listed in this chapter, check the Agilent Technologies Analytical Supplies Catalog or the on-line catalogue on the worldwide web at <http://www.agilent.com/chem>. If you still cannot find it, contact your Agilent Technologies service representative or your Agilent Technologies office.

## Electronics

The printed circuit boards in the MSD are available only as complete assemblies. Individual electronic components are not available. This section contains fuses. (See [Table 17.](#))

### Fuses

**Table 17** Fuses

Description	Part number
Fuse T12.5A, 250 V	2110-1398

## Vacuum System

This section lists replacement parts available for the vacuum system. It includes:

- O-rings and seals in [Table 18](#)
- Standard foreline pump and related components (See [Table 19](#) on page 219 and [Figure 50](#) on page 220.)
- Dry foreline pump and related components (See [Table 20](#) on page 221, [Table 21](#) on page 222, [Figure 51](#) on page 221, and [Figure 52](#) on page 223.)
- DP and related components (See [Table 22](#) on page 224 and [Figure 53](#) on page 224.)
- Turbo pump vacuum system components. (See [Table 23](#) on page 225 and [Figure 54](#) on page 225.)

### O-rings and seals

**Table 18** O-rings and seals

Description	Part number
Calibration valve O-ring (1/4-inch)	5180-4182
KF10/16 seal (foreline pump inlet and DP outlet), Micro-Ion vacuum gauge	KC16AV
KF50 seal (DP inlet)	0100-1884
Side plate O-ring	0905-1442
Vent valve O-ring (1/4-inch)	5180-4182

## Standard foreline pump and related parts

**Table 19** Standard foreline pump and related parts (Figure 50 on page 220)

Description	Part number
Pfeiffer RVP - 115 V	G3870-80055
Pfeiffer RVP - 230 V	G3870-80056
Pfeiffer RVP - 200 V	G6870-80054
Pfeiffer RVP - 115 V - Rebuilt	G3870-89055
Pfeiffer RVP - 230 V - Rebuilt	G3870-89056
Pfeiffer RVP - 200 V - Rebuilt	G6870-89054
Foreline hose assembly (hose and internal spring)	05971-60119
• Hose Clamp <sup>†</sup> used with 05971-60119	1400-3241
Foreline pump inlet seal (KF10/16)	KC116AV
KF10/16 Clamp (foreline inlet), Micro-Ion vacuum gauge	KC160000AB
Oil drip tray	G3170-00012
Drain plug for foreline pump	0100-2452
O-ring for foreline pump drain plug	0905-1619
Fill plug	0100-2451
O-ring for foreline fill plug	0905-1620
Blue mist filter	G1099-80039
Hose barb adapter (exhaust fitting)	G3170-80006
O-ring for oil mist filter and hose barb adapter	0905-1193
Foreline pump oil	6040-0621
5 mm hex key	8710-1838

<sup>†</sup> Hose clamps are interchangeable, but give an optimum fit if they are matched



**Figure 50** Pfeiffer DUO pump



## MVP-070 foreline pump and related parts

**Table 20** Dry foreline pump and related parts (Figure 51)

Description	Part number
Dry pump, MVP 070-3	G3870-80051
Dry pump, MVP 070-3C	G3870-80061
Dry pump, MVP 070-3 - Rebuilt	G3870-80052
Dry pump, MVP 070-3C - Rebuilt	G3870-89052

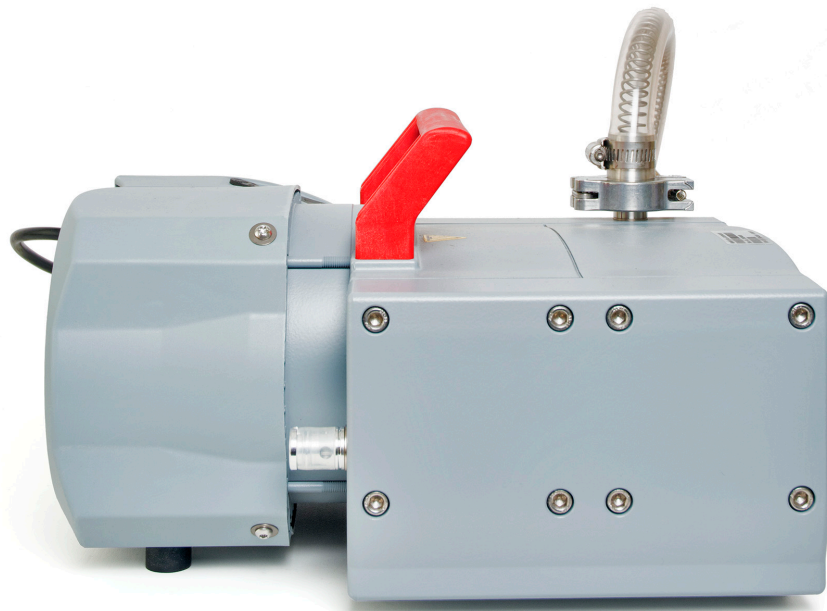

**Figure 51** MVP-070 foreline pump

## IDP3 Dry foreline pump and related parts

**Table 21** IDP3 foreline pump and related parts (Figure 52)

Description	Part number
Foreline hose assembly (hose and internal spring)	05971-60119
• Hose Clamp <sup>†</sup> used with 05971-60119	1400-3241
Dry foreline pump	G3870-60600
Replace tip seal set, non-ammonia	IDP3TS
Solid tip seal kit, inert	G3870-67000
KF10/16 Clamp (foreline inlet), Micro-Ion vacuum gauge	0100-1397
KF16 Hose adapter	G1099-20531
Vibration Isolation kit	IDP3VIBISOKIT
Exhaust hose	G3170-60100
Exhaust adapter	G3170-80029
Barbed fitting	G3170-80006
Exhaust hose for oil-less pump	G3170-60100

<sup>†</sup> Hose clamps are interchangeable, but give an optimum fit if they are matched



**Figure 52** IDP3 Dry foreline pump

**CAUTION**

Agilent does not recommend using hydrogen as a carrier gas on systems equipped with an IDP3 rough pump.

---

## DP and related parts

**Table 22** DP MSD vacuum system components (Figure 53)

Item	Description	Part number
1	DP	
	120 V	G1099-80500
	220/240 V	G1099-80501
2	Fan (for high vacuum pump)	G7005-60564
3	Foreline gauge assembly	G1099-60545
	KF50 clamp	0100-1395

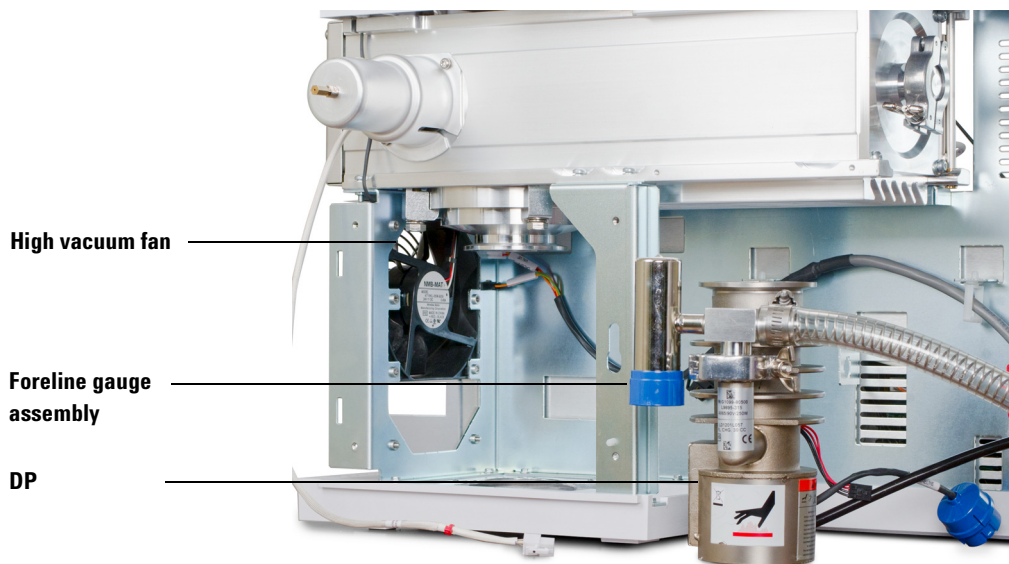
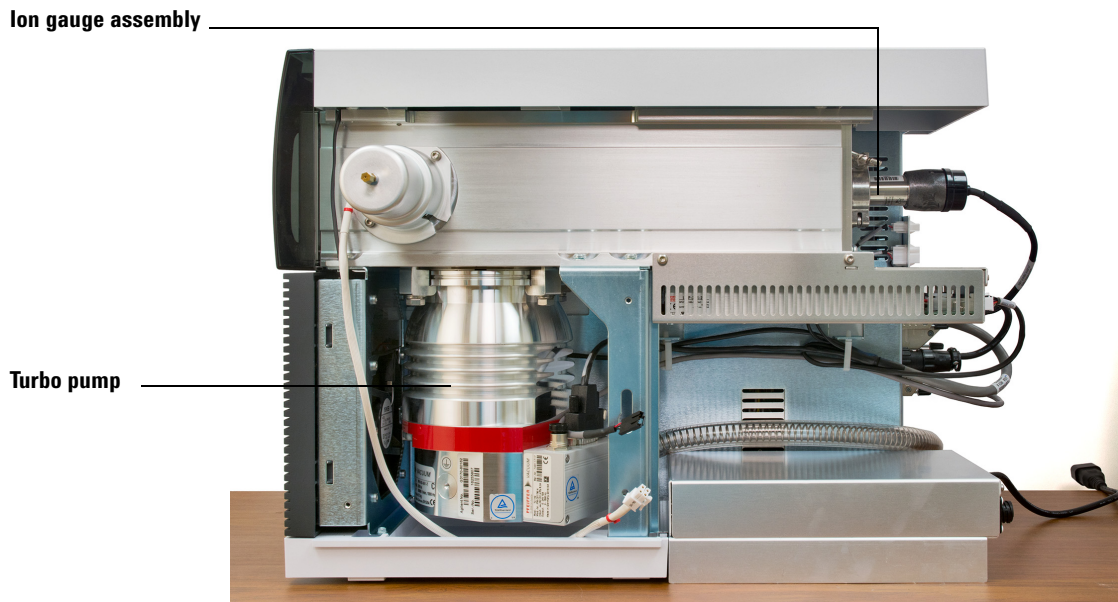

**Figure 53** DP removed from analyzer chamber connection and related parts

## Turbo pump and related parts

**Table 23** Turbo pump MSD vacuum system components (Figure 54)

Description	Part number
Turbo pump	G3170-80162
Pfeiffer HiPace 300 turbo pump- Rebuilt	G3170-89162
Turbo power assembly	G3170-60600
Centering ring seal with screen	0905-1613



**Figure 54** Turbo pump and related parts

## Analyzer

This section shows the analyzer chamber and associated parts. (See [Table 24](#) and [Figure 55](#).)

**Table 24** Analyzer chamber and related parts ([Figure 55](#))

Description	Part number
Calibration bulb	G3170-80002
Vent valve knob	G7077-20554

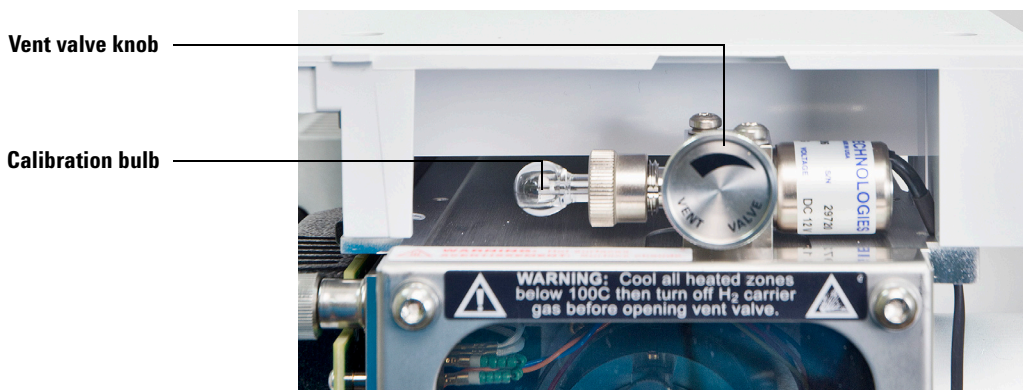

**Figure 55** Analyzer chamber and related parts

The replacement parts for the analyzer. (See [Table 25](#) and [Figure 56](#) on page 227.) Analyzer screws are listed in the tables that follow. (See [Table 26](#) on page 227.)

**Table 25** Analyzer parts ([Figure 56](#))

Description	Part number
TAD assembly (Detector, HED, bracket)	G7002-80105
Detector (Electron multiplier horn)	G7002-80103
El 350 source, new	
Turbo - inert	G3870-67700
Diffusion - stainless steel	G3870-67750

**Table 25** Analyzer parts (Figure 56) (continued)

Description	Part number
EI 350 XTR source	G3870-67720
HES source	G7002-67055
CI source	G7077-67404
Tip Seal	G3870-20542

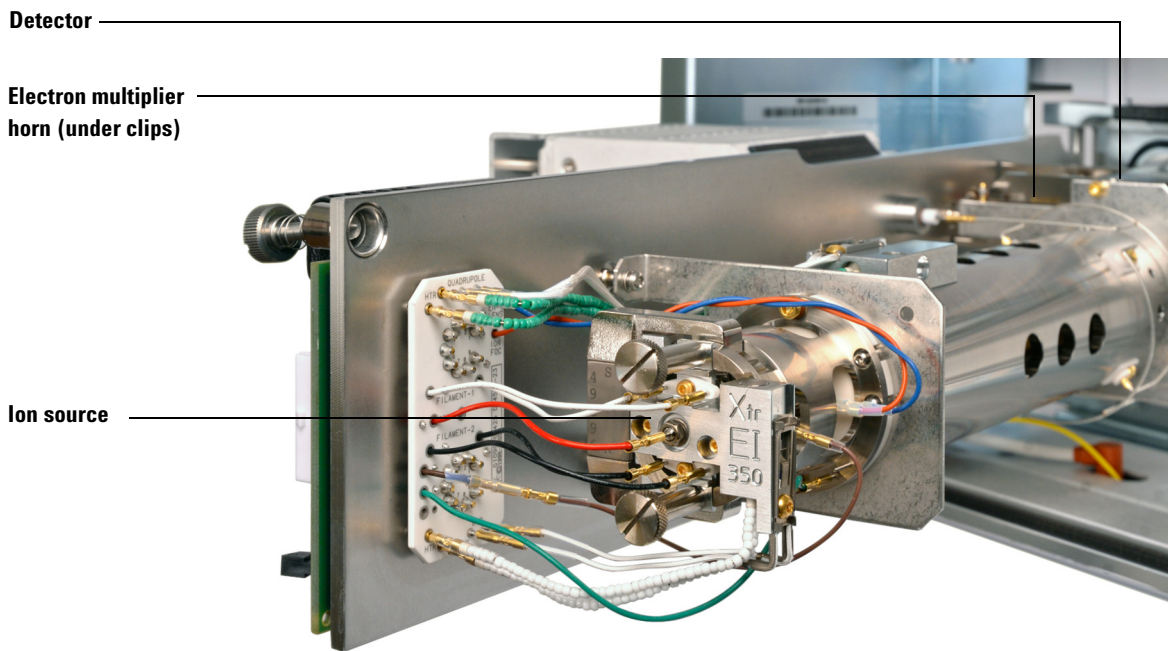

**Figure 56** Analyzer parts

**Table 26** Analyzer screws

Description	Part number
Ion source thumbscrew	G1099-20138

## El source

**Table 27** Parts list for the standard or inert El source (Figure 57 on page 229)

Item number	Item description	Part number (SSL)	Part number (Inert)
1	Gold plated set screw	G1999-20022	G1999-20022
2	Gold plated screw	G3870-20021	G3870-20021
3	Interface socket	G1099-20136	G1099-20136
4	Source body	G1099-20130	G2589-20043
5	Drawout cylinder	G1072-20008	G1072-20008
6	Drawout plate	05971-20134	G2589-20100
7	4-turn filament	G7005-60061	G7005-60061
8	Spring washer	3050-1374	3050-1374
8	Flat washer	3050-0982	3050-0982
9	Lens insulator	G3170-20530	G3170-20530
10	Entrance lens	G3170-20126	G3170-20126
11	Ion focus lens	05971-20143	05971-20143
12	Repeller insulator	G1099-20133	G1099-20133
13	Repeller	G3870-60172	G3870-60173
14	Flat washer	3050-0627	3050-0627
15	Belleville spring washer	3050-1301	3050-1301
16	Repeller nut	0535-0071	0535-0071
17	Source heater block assembly	G3870-60180	G3870-60179
18	Repeller block insert	G3870-20135	G3870-20135



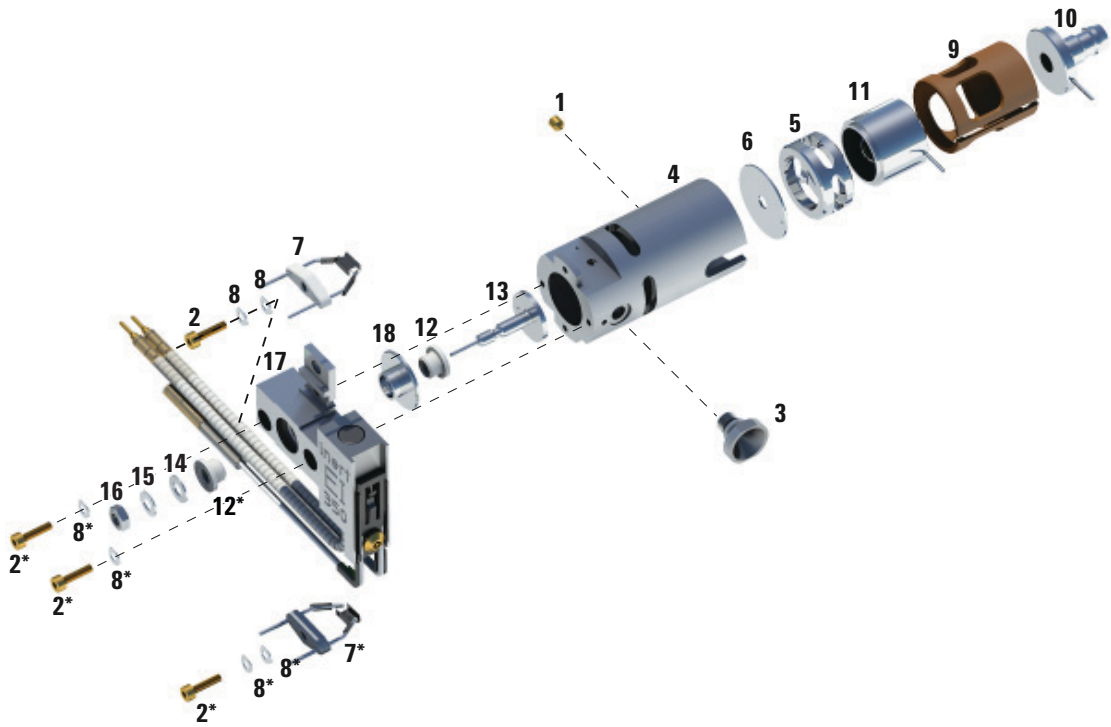

**Figure 57** Standard or inert EI source

## El XTR source

**Table 28** Parts list for El XTR source (Figure 58)

Item	Description	Part number
1	Setscrews	G3870-20446
2	Screws	G3870-20021
3	Source body	G3870-20440
4	Extractor lens	G3870-20444
5	Extractor lens insulator	G3870-20445
6	Filaments	G7005-60061
7	Spring washer	3050-1301
7	Flat washer	3050-0982
8	Lens insulator	G3870-20530
9	Entrance lens assembly, Extended	G7000-20026
10	Ion focus lens	05971-20143
11	Repeller insulator	G1099-20113
12	Repeller	G3870-60171
13	Flat washer	3050-0891
14	Belleville spring washer	3050-1301
15	Repeller nut	0535-0071
16	Source heater block assembly	G3870-60177
17	Repeller block insert	G3870-20135
Not shown	El XTR source assembly	G7003-67720



## CI source

**Table 29** Parts list for CI source (Figure 59)

Item	Description	Part number
1	Set screw	G1999-20022
2	Filament screw	G1999-20021
3	CI repeller insulator	G1999-20433
4	CI lens insulator	G3170-20540
5	CI drawout cylinder	G1999-20444
6	CI drawout plate	G1999-20446
7	CI source heater block assembly	G3870-60415
8	Entrance lens	G7000-20026
9	CI source body	G3170-20430
10	Ion focus lens	G1999-20443
11	CI repeller	G7077-20432
12	CI filament- 2PK	G7005-60072
13	Dummy filament	G1999-60454
14	Washer spring curved 2.2 mm-ID 4.5 mm-OD 0 Qty. 2	3050-1374
15	Flat washer	3050-9082
Not shown	Package, GC source Clamshell	G7002-80008
Not shown	Bracket, GC source, Clamshell	G7002-00008
Not shown	350 CI source assembly	G7002-67404
Not shown	350 CI source assembly (without tip seal)	G7077-67404

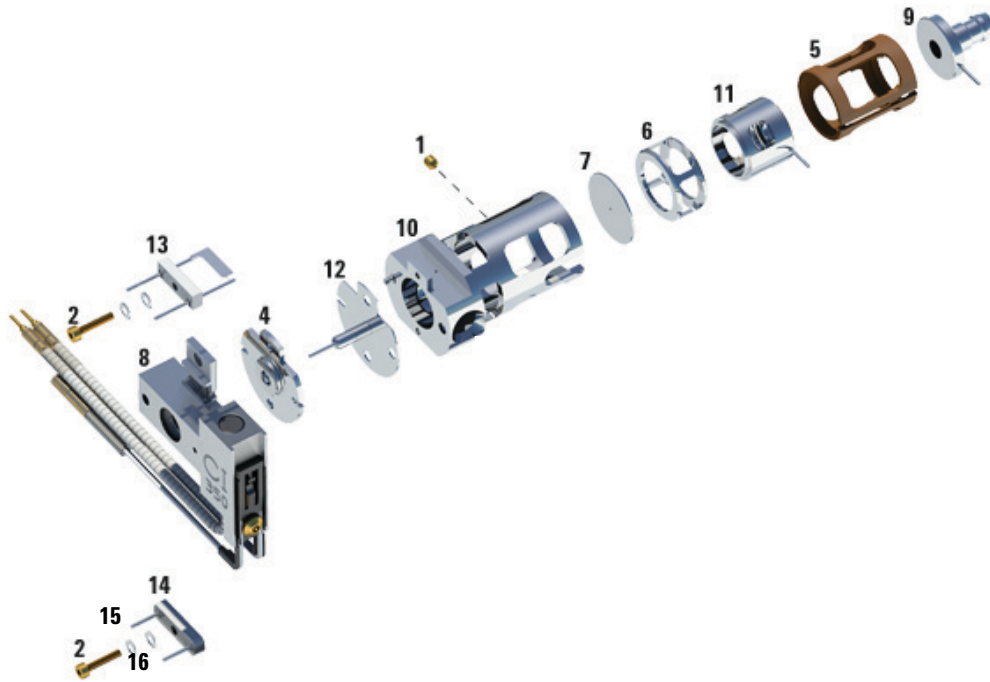

**Figure 59** The CI source

## The EI HES source

**Table 30** Parts list for EI HES (Figure 60)

Item number	Item description	Part number
1	Source finger grip	G7002-20008
2	Filament block	G7002-20019
3	Extractor lens (5)*, with 3 mm opening	G7002-20061
4	Ceramic insulator for extractor	G7002-20064
5	Entrance lens assembly, Extended, HES (1)*	G7002-20165
6	Ion focus lens (2)*	G7002-20068
7	Lens insulator/holder	G7002-20074
8	M2 x 0.4 screw x 12 mm long gold plated screw	G7002-20083
9	Source body	G7002-20084
10	Post extractor lens 2 (3)*	G7002-20090
11	Post extractor lens 1 (4)*	G7002-20104
12	M2 x 6 mm gold plated screw	G7002-20109
13	Locking ring lens insulator	G7002-20126
14	High efficiency dual filament	G7002-60001
15	Ring heater/sensor assembly	G7002-60043
16	Source mount 1.5 mm	G7002-60053
17	Repeller assembly	G7002-60057
Not shown	HES assembly	G7004-67055

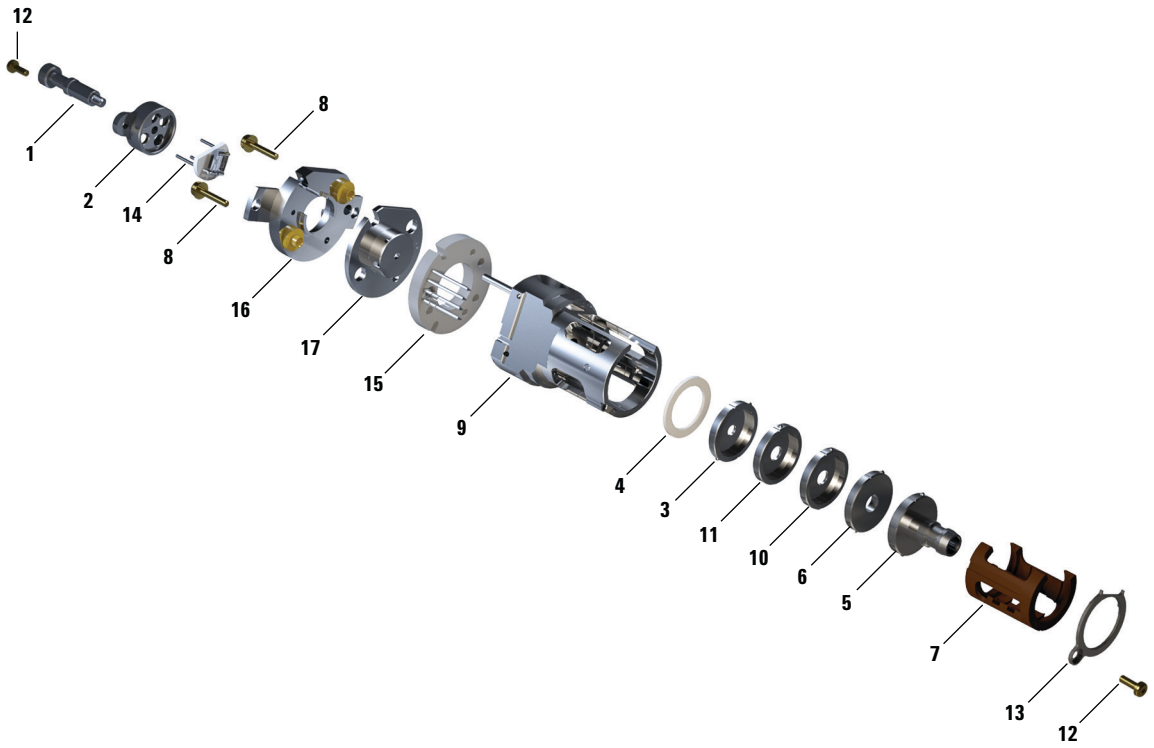

Figure 60 EI HES source

## EI GC/MSD Interface

A list of the replacement parts related to the EI GC/MSD interface and an illustration of the parts is also provided. (See [Table 31](#) and [Figure 61](#) on page 237.)

**Table 31** EI GC/MSD interface ([Figure 61](#) on page 237)

Item	Description	Part number
Not shown	EI Transferline Assembly	G7077-67300
1	Transferline tip cap, threaded	G3870-20547
2	1/16 Ferrule no hole (qty 10)	5181-3308
3	M3 set screw	0515-0236
4	Transferline tip base, threaded	G3870-20548
5	Transfer tip	G3870-20542
6	Column nut	05988-20066
7	M3 screw	G1999-20022
8	M4 X 0.7 16MM-LG	0515-0383
9	Heater clamp	G7077-20210
10	Transfer line spring	G1999-20023
11	Welded interface assembly	G3870-60301
12	Heater/sensor assembly	G1099-60109



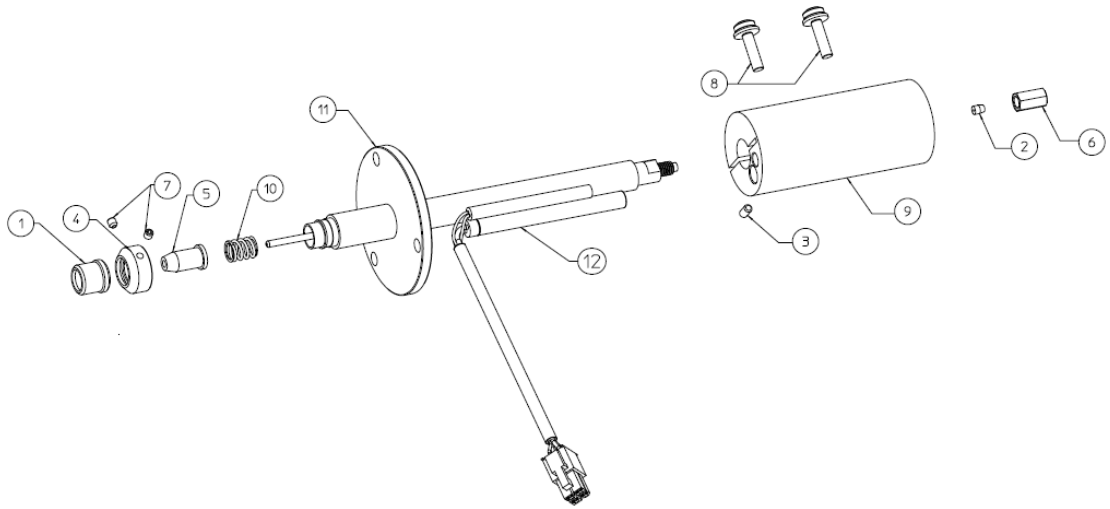

**Figure 61** EI GC/MSD interface

## CI MSD Interface

A list of the replacement parts related to the CI GC/MSD interface and illustration of the parts is provided. (See [Table 32](#) and [Figure 62](#) on page 239.)

**Table 32** CI GC/MSD interface ([Figure 62](#) on page 239)

Item	Description	Part number
Not shown	CI Transferline Assembly, untested	G7077-67400
1	Transferline tip cap, threaded	G3870-20547
2	1/16 Ferrule no hole (qty 10)	5181-3308
3	M3 set screw	0515-0236
4	Transferline tip base, threaded	G3870-20548
5	Transfer tip	G3870-20542
6	Column nut	05988-20066
7	M3x3L screw-set, gold plated	G1999-20022
8	M4 X 0.7 16MM-LG screws for heater clamp	0515-0383
9	Heater clamp	G7077-20410
10	Transfer line spring	G1999-20023
11	Welded interface assembly	G3870-67401
12	Heater/sensor assembly	G1099-60107

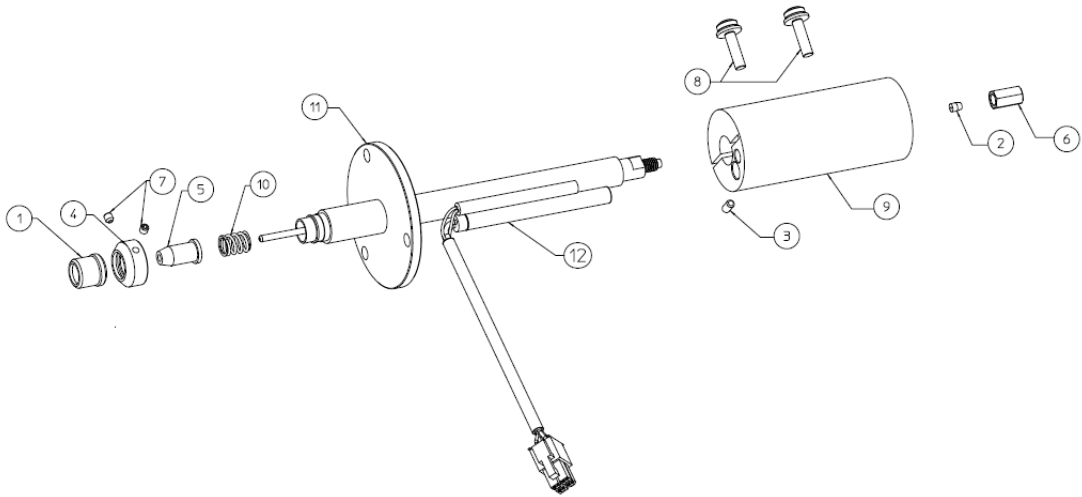

**Figure 62** CI GC/MSD interface

## Consumables and Maintenance Supplies

This section lists parts available for cleaning and maintaining your MSD. (See Tables 33 through 37.)

**Table 33** El maintenance supplies

<b>Description</b>	<b>Part number</b>
Abrasive paper, 30 µm	5061-5896
Alumina powder, 100 g	3937-6201
Cloths, clean (qty 300)	05980-60051
Cloths, cleaning (qty 300)	9310-4828
Cotton swabs (qty 100)	5080-5400
DP fluid (2 required)	6040-0809
Foreline pump oil, D545, 0.5 L	6040-0621
,IDP-3 foreline pump replacement tip seal kit	IDP3TS
IDP-3 foreline pump 24V Power Supply	G3870-60600
Gloves, clean – Large	8650-0030
Gloves, clean – Small	8650-0029
Grease, Apiezon L, high vacuum	6040-0289

**Table 34** Tools

<b>Description</b>	<b>Part number</b>
Column installation tool	G1099-20030
Funnel	9301-6461
Hex key, 5 mm	8710-1838
Tool Kit	G1099-60566
Ball drivers, 1.5-mm	8710-1570
Ball drivers, 2.0-mm	8710-1804
Ball drivers, 2.5-mm	8710-1681
Hex nut driver, 5.5-mm	8710-1220
Pliers, long-nose (1.5-inch nose)	8710-1094
Screwdrivers Flat-blade, large	8730-0002
Screwdrivers Torx, T-6	8710-2548
Screwdrivers Torx, T-10	8710-1623
Screwdrivers Torx, T-20	8710-1615
Tweezers, nonmagnetic	8710-0907
Wrenches, open-end 1/4-inch x 5/16-inch	8710-0510
Wrenches, open-end 10-mm	8710-2353

**Table 35** Ferrules

Description	Part number
For the GC/MSD interface using a standard column nut	
• Blank, graphite-vespel	5181-3308
• 0.3-mm id, 85%/15% for 0.10-mm id columns	5062-3507
• 0.4-mm id, 85%/15%, for 0.20 and 0.25-mm id columns	5062-3508
• 0.5-mm id, 85%/15%, for 0.32-mm id columns	5062-3506
• 0.8-mm id, 85%/15%, for 0.53-mm id columns	5062-3538
For the GC/MSD interface using a self tightening column nut	
• Blank, graphite-vespel	5181-3308
• 0.3-mm id, 85%/15% for 0.10-mm id columns	5062-3507
• 0.4-mm id, 85%/15% for 0.0 and 0.25-mm id columns	5062-3508
• 0.5-mm id, 85%/15% for 0.32-mm id columns	5062-3506
• 0.8-mm id, 85%/15% for 0.53-mm id columns	5062-3512

**GC/MSD interface with  
self-tightening nut**

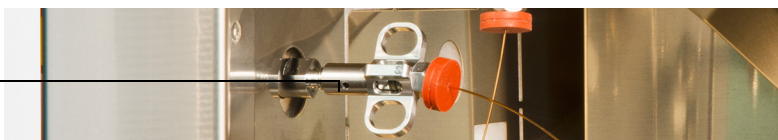
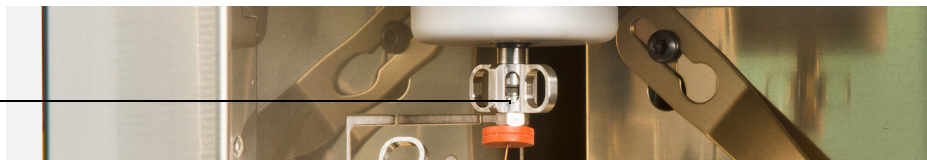

**Figure 63** GC/MSD interface with a self tightening column nut

**Table 36** Ferrules for the GC inlet, using standard or self tightening column nuts

Description	Part number
• 0.27-mm id, 90%/10%, for 0.10-mm id columns	5062-3518
• 0.37-mm id, 90%/10%, for 0.20-mm id columns	5062-3516
• 0.40-mm id, 90%/10%, for 0.25-mm id columns	5181-3323
• 0.47-mm id, 90%/10%, for 0.32-mm id columns	5062-3514

GC inlet with self  
tightening nut

**Figure 64** GC inlet with self tightening column nut

**Table 37** Miscellaneous EI and CI parts and samples

<b>Description</b>	<b>Part number</b>
Foreline exhaust oil mist trap	G1099-80039
Benzophenone, 100 pg/ $\mu$ L	8500-5400
OFN, 1 pg/ $\mu$ L	5188-5348
OFN, 100 fg/ $\mu$ L	5188-5347
OFN, 10 fg/ $\mu$ L	5190-0585
PFHT, 100 pg/ $\mu$ L	5188-5357
PFTBA, 10 g	8500-0656
PFTBA sample kit	05971-60571
PFDTD calibrant	8500-8510
Foreline pump tray (Pfeiffer pump)	G1099-00015
Duo 2.5s and DS-42 foreline pump oil pan	G3870-00015
Eval A, hydrocarbons	05971-60045
Ion gauge electronics	G3870-80030
Methane/isobutane gas purifier	G1999-80410
Wipes (qty 300)	9310-4828







**Agilent Technologies**

© Agilent Technologies, Inc.

Printed in USA, June 2016



G7077-90025